

Railway Current & Voltage Transducers

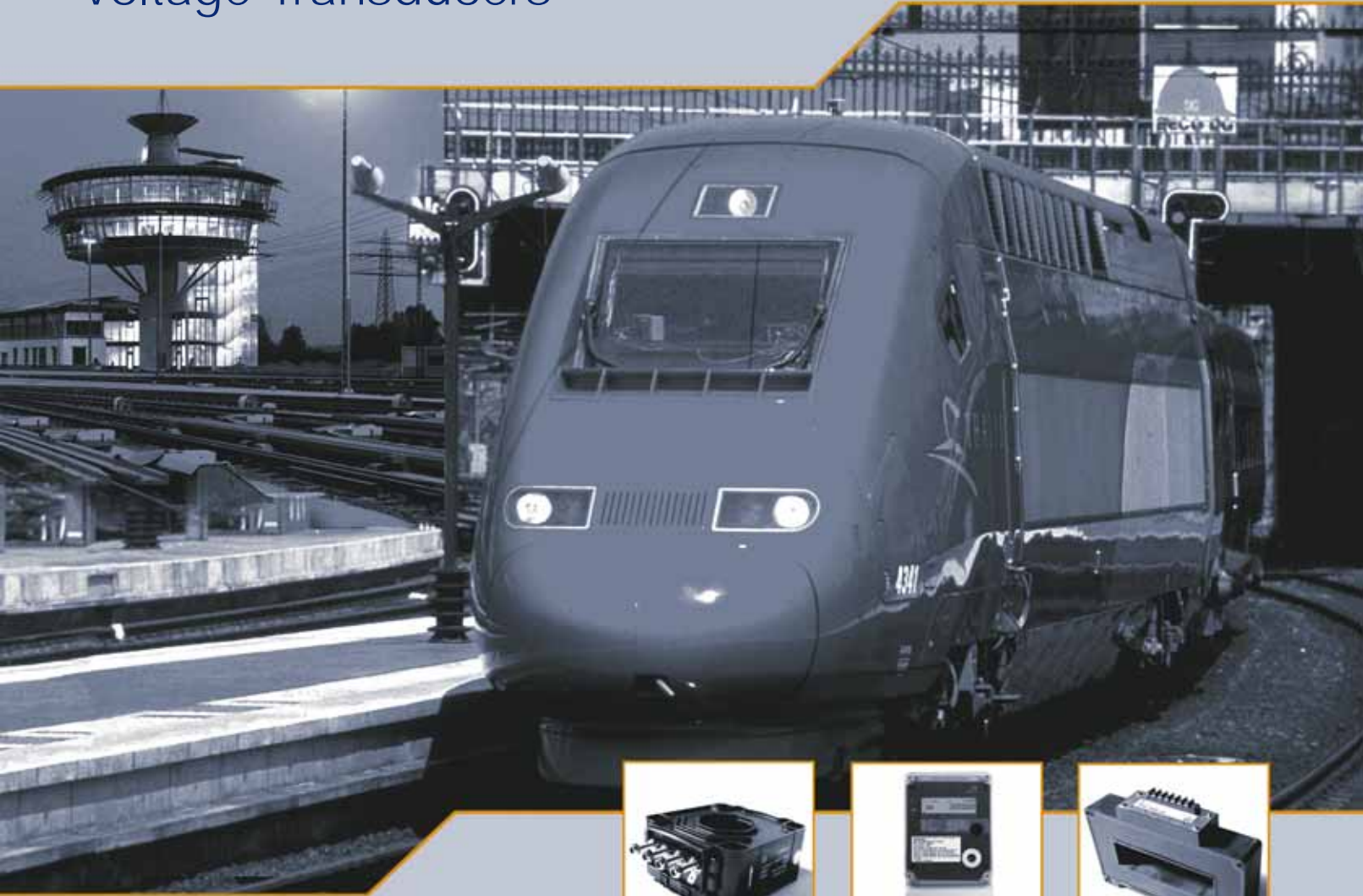

Current and Voltage Transducers for Railway applications

LEM solutions for traction electrical measurements

This catalogue summarizes the most common LEM product offerings for electrical railway measurements. It is our business to support you with both standard and customized products to optimize your application.

Please contact LEM in your region for assistance.

Today, high speed trains, city transit systems (metro, trams, and trolleybuses) and freight trains are the solutions against pollution and interstate traffic immobility and provide a significant energy savings.

Power electronics is essential to drive and control energy in these transportation systems.

LEM has been a main player in traction power electronics applications and development for the last 30 years and leverages this vast experience to supply solutions for isolated current and voltage measurements.

LEM transducers provide control and protection signals to power converters and inverters

that regulate energy to the electric motors (for propulsion) and to the auxiliaries (for air-conditioning, heating, lighting, electrical doors, ventilation, etc.). This includes the early monitoring of the voltage network (changing by crossing the European borders) to make the powers electronics working accordingly.

Although this is true for on-board applications, LEM has also provided the same control and protection signals for wayside substations.

The rail industry is under constant changes and evolution. As a recent example, the privatization of the rail networks raised new requirements for which LEM provides: the on-board monitoring of power consumption (EM4T Energy Meter), solutions to trackside applications, rail maintenance and the monitoring of points (switches) machines or signaling conditions with some new transducers families.

LEM is always available to assist in adapting to these evolving

technical applications.

Three decades of railway experience has contributed to establishing LEM as a market leader with worldwide presence to serve you and provide the efficient, safe and reliable operation of the railways.

With more than 2 500 current and voltage transducers in its portfolio, LEM offers a complete range of accurate, reliable and galvanically isolated devices for the measurement of currents from 0.1 A to 20000 A and voltages from 10 V to 6 400 V in various technologies: Open Loop, Closed Loop, Isolation amplifier, etc.

LEM transducers for railway applications are designed according to the most demanding international standards (EN50155, EN50124-1, NFF 16101, 16102, etc) and carry CE marking. UL or UR is also available on selected models.

We have worldwide ISO 9000 and ISO TS 16949:2002 (Geneva production and design

center, Beijing LEM planned for 2007) qualification and offer a 5-year warranty on all of our products.

LEM constantly innovates and strives to improve the performance, cost and sizes of its products.

LEM is a worldwide company with offices across the globe and production facilities in Europe (included Russia), Asia and America.

We hope you will find this catalogue as a useful guide for the selection of our products. Visit our website at www.lem.com and contact our sales network for further assistance. Detailed datasheets and application notes are available.

Sincerely,

Luc Colombel
Vice President & Business
Segment Manager Traction

Paul Van Iseghem
President & CEO LEM

Content	Pages
Transducer Technologies	4 - 5
On-Board Applications	6 - 13
Substations	14 - 17
Energy Measurement for On-Board Applications : EM4T	18 - 21
Specific Railway Applications	22 - 23
Mining Trucks Applications	24 - 25
Trackside Applications	26 - 29
LEM's Quality & Standards	30 - 31
Solutions for Voltage Measurement	32 - 33
From the Application to the Product	34 - 35
Secondary Connections Options	36
Design Specification Form	37
Dimension Drawings	38 - 42
LEM's Warranty	43
LEM International Sales Representatives	44

Transducer Technologies

Operation principle O/L

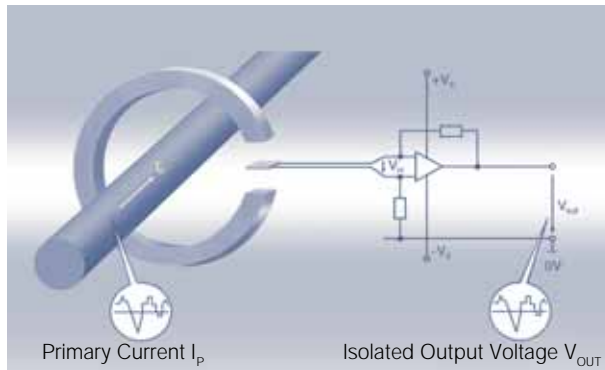

Open Loop Current Transducers (O/L)

Features

- Small package size
- Extended measuring range
- Reduced weight
- Low power consumption
- No insertion losses

The magnetic flux created by the primary current I_p is concentrated in a magnetic circuit and measured in the air gap using a Hall device. The output from the Hall device is then signal conditioned to provide an exact representation of the primary current at the output.

Operation principle C/L

Closed Loop Current Transducers (C/L)

Features

- Wide frequency range
- Good overall accuracy
- Fast response time
- Low temperature drift
- Excellent linearity
- No insertion losses

The magnetic flux created by the primary current I_p is balanced by a complementary flux produced by driving a current through the secondary windings. A hall device and associated electronic circuit are used to generate the secondary (compensating) current that is an exact representation of the primary current.

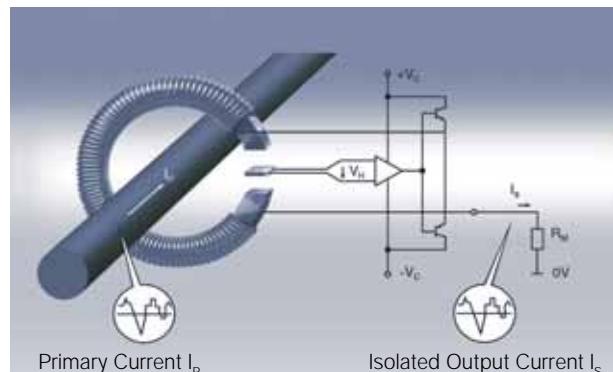

Closed Loop C Types

Operation principle

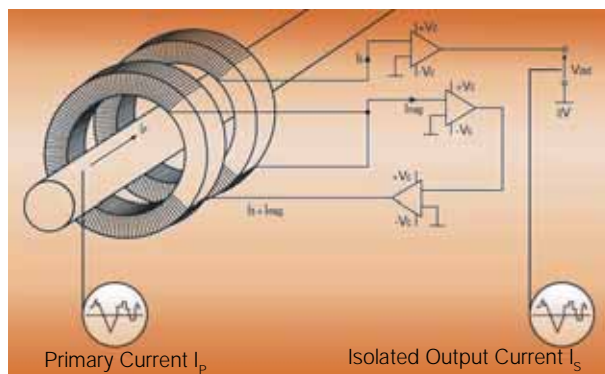

Features

- High accuracy
- Very wide frequency range
- Reduced temperature drift
- Excellent linearity
- Measurement of differential currents (CD)
- Safety isolation (CV)
- Reduced loading on the primary (CV)

This technology uses two toroidal cores and two secondary windings and operates on the principle of Ampere-turns compensation. For the voltage type a small (few mA) current is taken from the voltage line to be measured and is driven through the primary coil and the primary resistor.

Closed Loop Voltage Transducers (C/L)

Features

- Measurement of high voltages
- Safety isolation
- Good overall accuracy
- Low temperature drift
- Excellent linearity

A very small current limited by a series resistor is taken from the voltage to be measured and is driven through the primary coil. The magnetic flux created by the primary current I_p is balanced by a complementary flux produced by driving a current through the secondary windings. A hall device and associated electronic circuit are used to generate the secondary (compensating) current that is an exact representation of the primary voltage. The primary resistor (R_1) can be incorporated or not in the transducer.

Operation principle C/L

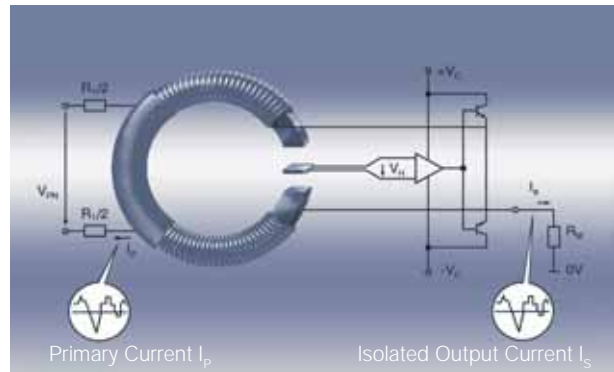

Operation principle

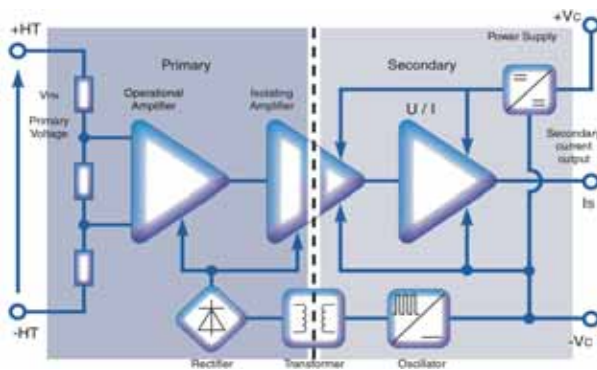

AV 100 types Voltage Transducers

Features

- Any kind of signal, DC, AC, pulsed and complex can be measured
- Galvanic isolation
- Short dynamic response for a good frequency bandwidth
- Fast response time
- Small volume needed

The voltage to measure (V_p) is directly applied on the primary connections through an internal resistor network and some components allowing the signal to feed an isolation amplifier.

An isolated signal is recovered and conditioned to supply a current at the output, which is an exact representation of the primary voltage.

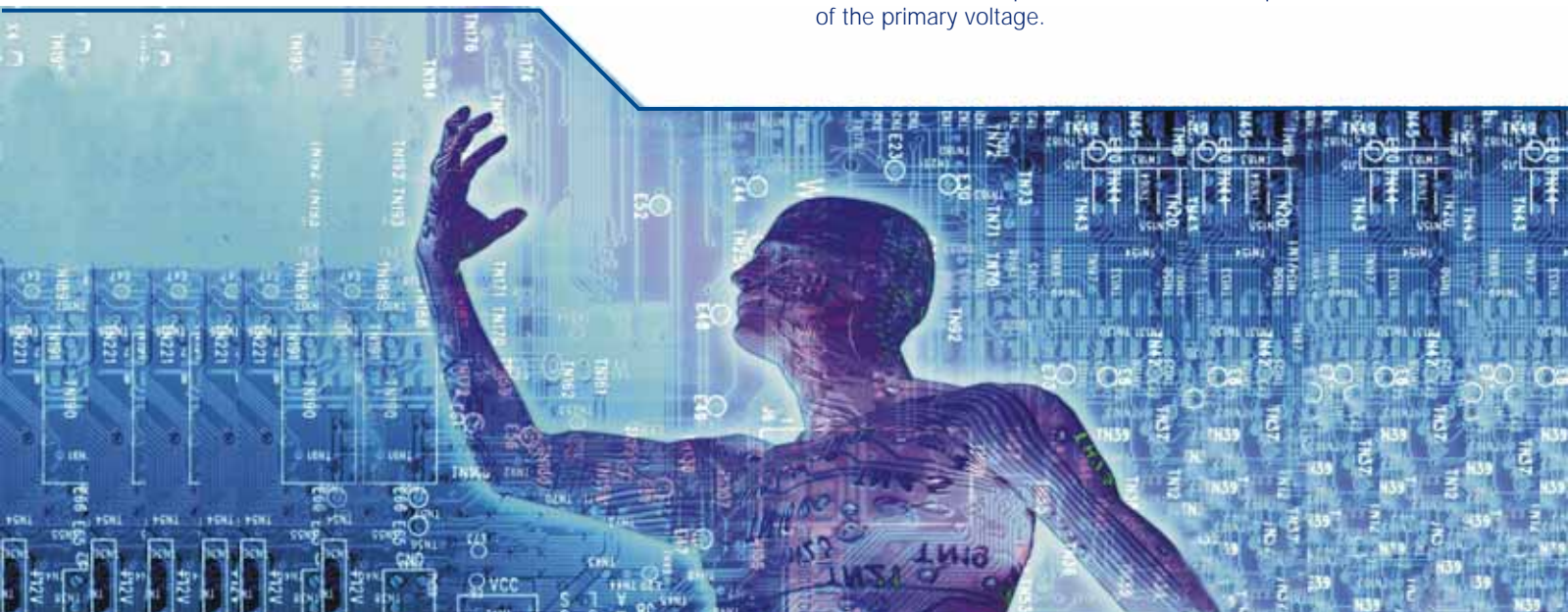

On-Board Applications

The electrical power is supplied to the trains via the catenaries.

So, depending on the country and also to the applications (Subway, trolleybuses, high speed train, heavy traction...) the locomotives can operate at different voltage levels and under different systems.

1. Rolling Stock Heavy Traction

Heavy traction means high speed, or long distances, or heavily loaded cars (freight trains).

For new lines, not part of an already existing network, AC voltage is often the choice.

Heavy traction rolling stocks are made up of (figure 1):

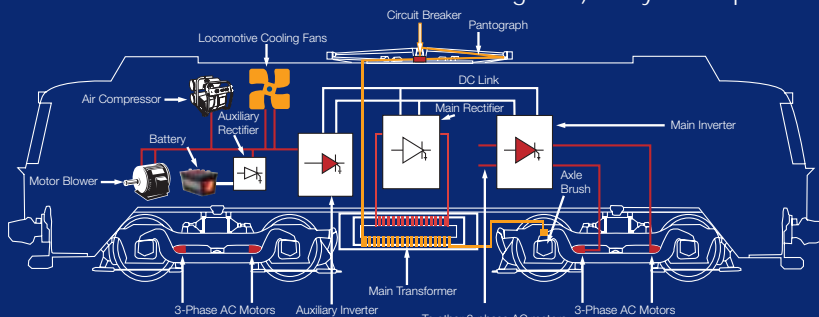

Figure 1: Various parts of an AC electric locomotive

- Main transformer,
- Main rectifier,
- DC link to make the connection to the Main Inverter and Auxiliary Inverter,
- Main Inverter,
- Auxiliary Inverter.

Main Transformer

Power from the catenaries route through the main circuit breaker before reaching the main transformer. This is the first place where a current transducer can be advantageous: The control of the input current (N°1a in the figure 2). The **LT 2005 & 4000** models bring the necessary advantages for that job: a large aperture for cable pass-through of the primary conductor as well as high isolation voltage.

Although it is a complex undertaking to design a train capable of operating in different

countries with various electrical railway catenary voltages, it has been possible due to advances in modern power electronics.

Eurostar, for example, is able to run over four different voltages, 25 kV/AC/50 Hz, 3 kV DC, 1.5 kV DC and 750 V DC.

The **LV 100-Voltage** series used at this level allows the detection of the voltage network, informing about the country where is running the locomotive (N°:1c in the figure 2).

To ensure the protection of the whole system, the earth leakage current to the wheels is also monitored thanks to special current transducers called **CD** series dedicated for that function (N°:1b in the figure 2). They are responsible

for measuring differential current between 2 or 3 conductors and detecting possible leakage between these conductors.

It is also possible to accomplish this measurement by using 2 typical traction current transducers like the **HAR 1000** or **LT 2005** families.

Multi winding transformers convert the catenary voltage to a voltage compatible with the power converters.

To get the best efficiency of the energy provided by the network, accurate and reliable measurement is required. LEM proposes the adapted measurement tool "**EM4T**", adapted to various European networks (please see section dedicated to **EM4T**). One of the secondary windings of this transformer is used to build a four-quadrant controller.

Main Rectifier

This is generally made up by a four quadrant controller to be connected to the DC link.

A four quadrant controller can regulate the flow of energy from the AC line to the DC link and from the DC link back to the AC line. It allows to have the power, taken from the catenaries, nearly close to the maximum theoretical value for a given current and this over a large range of speed and traction effort. In simple terms, this is an active rectifier.

This step is necessary for the 15 kV/AC/16Hz 2/3 and 25 kV/AC/50Hz networks, in order to decrease the voltage level, and, also, to convert the voltage to a DC value, which has been defined as the best compromise for the voltage/current supplied to today's semiconductors. 2000 V is a

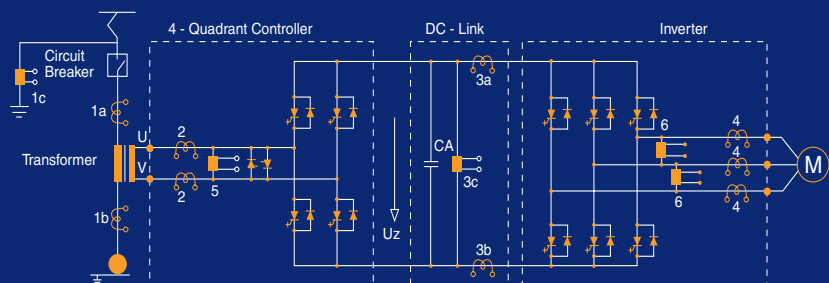

Figure 2: Where is the current and voltage measurement on the traction drive system ?

No contact and galvanically isolated differential measurement with a large aperture for multiple primary conductors result in safety-friendly transducers and accurate measurement.

typical value at this stage of the voltage transformation.

The control of the input voltage (main transformer output) is ensured by **LV 100-Voltage** or **CV 4-Voltage** transducers (N°:5 in the figure 2).



500 A

LTC FAMILY

1000 A

350 A

500 A

Mounting flexibility horizontal or vertical
Multiple options for a full modularity

Various secondary connections

Various busbars

Various feet



One current transducer may be used for the input current measurement to control and protect the four quadrant controller (N°:2 in the figure 2) such as models derived from **LTC 1000** or **LT 1005** Series.

DC Link

This is the link between the main rectifier output and the propulsion inverter input and the auxiliary inverter.

Its goal is to smooth the DC signal, limit the voltage (overloads), and/or filter the perturbations coming from the source (catenary/transformer) to the inverter or vice-versa.

A voltage transducer derived from the **LV 100-Voltage** family can be used for these functions (there are many models available for 2000 V measurement which is a typical value at this level) (N°:3c in the figure 2). **AV 100** Series transducers can also be a solution if frequency to follow is higher. The polarity on the DC link is also a controlled parameter.

Current overloads and polarity are also monitored by some current transducers to avoid power semiconductor damage (N°:3a in the figure 2): **LT 1005**, **2005**, **LTC 1000** and **LF 2005** families.

In the case of a direct DC voltage supplied by the catenaries (no transformer, no rectifier) (for subways, or trolleybuses for example, voltage line between 600 to 900 V DC), the DC link could then be made up of a simple inductance and some capacitors (**LV 100-Voltage** transducers range covers also these values as well as the **LV 25-Voltage** models) (N°:3c in the figure 2).

As for measurement of differential leakage currents at this level, the **CD** series transducers would satisfy the requirement (N°:3b in the figure 2).

Main Inverter or Drive Propulsion Inverter

In the past, some other propulsion principles were running using series DC current motors. Initially, the adjustment of the motor speed and torque was controlled by switched series resistors (figure 3).

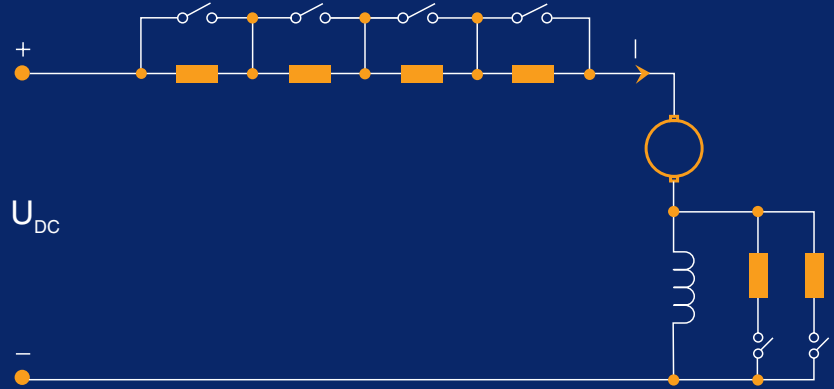

Figure 3 : DC motor control per resistors adjustment

Years later, choppers appeared with the use of the semiconductors (thyristors, then GTO thyristors or IGBT transistors). This last propulsion system is still often used today for railway traction (figure 4).

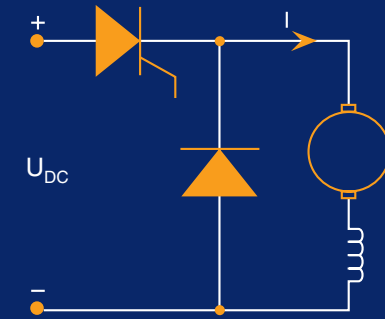

Figure 4 : DC motor control per chopper

Today, however, the most popular way to propel the train is the asynchronous motor where the power is supplied by inverters.

Indeed, asynchronous motors bring advantages such as compactness, robustness, less expensive for maintenance, and increased productivity. (Synchronous motors are also often used for TGV propulsion for example).

The inverter is transforming the DC voltage supplied by the DC link into an AC voltage for a three phase system.

The frequency and amplitude of the root (base) signal can then be adjusted.

The most used inverter today is the

PWM (Pulse Width Modulation) inverter. This is made up of six electronic switches (initially GTOs followed by IGBTs) as represented in figure 5.

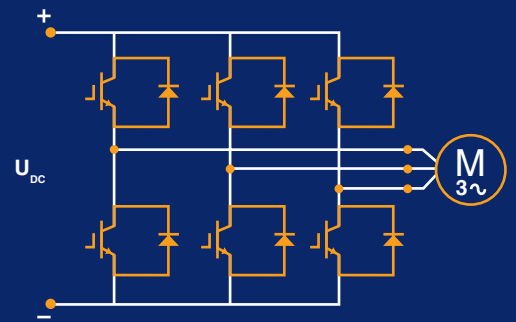

Figure 5 : AC motor control per PWM inverter

The switching frequency is normally as high as possible.

The motor voltage follows a sinusoidal profile and the fundamental frequency of the current and the voltage supplied are functions of the required motor speed. Depending on the required torque, voltage and current amplitudes fluctuate with the frequency.

To control these motor current parameters, **LTC** current transducers located on each phase of the asynchronous motor, fulfill all



Fret Propulsion Inverter
Copyright ALSTOM

ChC Screw M5x25 (x2)
 Flat washer (x2)

Lines	Accessories	References
1	Busbar KIT* (busbar : 210 x 40 x 12 mm)	93.34.61.100.0
2	Busbar KIT* (busbar : 185 x 40 x 8 mm)	93.34.61.102.0
3	Busbar KIT* (busbar : 285 x 36 x 12 mm)	93.34.61.103.0
4	Busbar KIT* (busbar : 260 x 36 x 12 mm)	93.34.61.104.0
5	Busbar KIT* (busbar : 195 x 36 x 10 mm)	93.34.61.105.0
6	Busbar KIT* (busbar : 38 mm \varnothing x 325 mm)	93.34.61.106.0
7	Busbar KIT* (busbar : 185 x 40 x 10 mm)	93.34.61.107.0
8	Busbar KIT* (busbar : 180 x 40 x 12 mm)	93.34.61.108.0
9	Busbar Fastening Kit (M5 x 25)** dedicated to busbars from lines 1 to 5 and lines 7, 8	93.34.61.200.0
10	Busbar Fastening Kit (M5 X 40)** dedicated to busbar from line 6	93.34.61.201.0
11	Feet fixing Kit ***	93.34.63.100.0

Flat washer (x2)
 Spring washer (x2)
 Nut M5 (x2)
 Tightening torque Max. 2.4Nm

Bar
 Clamp (x2)
 Foot (x2)

PT Screw KA 35x30 (x2)
 Tightening torque Max. 1Nm

Other possibilities of assembly for Feet, Bar and Clamps

* including all the necessary for its mounting such as screws, washers, nuts, 2 clamps, busbar.
 ** as with * but without the busbar.
 *** including screws and 2 feet.

LTC 600 & 1000 Transducer / Mechanical adaptation accessories

ChC Screw M4x30 (x2)

Accessories	References
Busbar Kit* (busbar : 155 x 25 x 6 mm)	93.34.41.100.0
Busbar Kit** (busbar : 112 x 25 x 6 mm)	93.34.41.101.0
Busbar Fastening Kit**	93.34.41.200.0
Feet fixing Kit***	93.34.43.100.0

Spring Washer (x2)
 Washer (x4)
 Nut M4 (x2)
 Tightening torque Max: 1.5Nm

Bar
 Clamp (x2)
 Foot (x2)

PT Screw KA35-25 (x2)
 Tightening torque Max: 1Nm

Other possibilities of assembly of Feet, Bar and Clamps

* including all the necessary for its mounting such as screws, washers, nuts, 2 clamps, busbar.
 ** as with * but without the busbar.
 *** including screws and 2 feet.

LTC 350 & 500 Transducer / Mechanical adaptation accessories

the railway requirements for 350 to 1000 A nominal current measurements (N°:4 in the figure 2): The **LTC** is modular, compact, designed for traction, many possibilities of secondary connections, and fully approved for traction.

The **LT 505**, 1005, and **2005** series are also recognized for this function, and have been used for several years in these applications. The higher the chopping frequency, the more sinusoidal is the current waveform.

The choice of a Closed Loop Hall effect based transducer is justified:

- to get a fast response time (for protection purpose),
- to "see" and support high frequency signals of the current (ripple on the fundamental) from the high switching frequency of the inverter,
- and to achieve accurate control of the speed.

Several propulsion motors can be connected in parallel at the inverter output.

Depending on the equipment manufacturer, some techniques are possible to improve the voltage waveform applied to the motor or to decrease the motor harmonic currents.

The PWM inverter output phase voltages can also be controlled with help from two voltage transducers derived from the **LV 100-Voltage**, **AV 100-Voltage** or **CV-Voltage** families for speed control (N°:6 in the figure 2).

Auxiliary Inverter

Auxiliary inverters are the systems supplying other on-board loads. Although, not as popular, they are essential to the auxiliary loads needed for the propulsion and for the passengers' comfort.

Depending on the catenary voltages on the applied loads at the output, on the constraints dictated by the car itself (where it will be mounted : On the roof, into the floor...) or by the application (environment)..., the electronic schematics for the

auxiliary inverters are various, and, they use in all the cases all the last innovations of the power electronics. They have to bring the following advantages to the application:

- Compact,
- Light weight,
- High yield, low cost and low maintenance,
- High performance.

For DC power, auxiliary inverters can be fed directly from the catenaries and for AC power, they can be connected to the main transformer through a secondary winding, but can also be connected to the main or intermediate rectifier output.

By converting the voltage and current under various waveforms (DC, AC, different frequencies, stable or variable frequency), they have the responsibility to supply systems such as:

- Batteries: The DC voltage provides charge to the battery at different values depending on the country and the traction vehicle (24, 48, 72 or 110 V being the most widely used). The batteries are used to provide start-up current, for emergency lighting when the line supply fails, or to supply power to other auxiliary circuits. Charging and discharging of the batteries are monitored by voltage transducers. Depending on the accuracy needed for this type of monitoring, various models are available. The **CV 3** models are designed for high accurate measurement throughout their measuring ranges followed by the **AV 100** and **LV 100-Voltage** models.
- Resistances and windings,
- Motors: DC or even AC motors operating under three phases 380-400 V/50-60 Hz for car ventilation, traction motors fans and traction compartment fans, blowers, pumps, compressors, etc. The start-up and shutdown of these motors are automatically controlled by other

on-board systems but still require current overload support from the auxiliary inverter.

- Various electronics: AC single-phase power supplies control power, power plugs, lighting, etc. These voltages have to be filtered and stabilized since the catenary voltages can fluctuate. The auxiliary inverter must sustain any high transient overvoltages that may occur.
- Transformers...

Additionally, these systems support the operation of HVAC heating and doors openers while having to operate from several possible voltage networks for European cars.

The passenger's comfort is represented more and more in these systems and consequently increases the overall energy requirements. The auxiliary inverters have to rationalize the best energy consumption by using the latest power electronics technology and take advantage of any possible energy savings.

For the previous mentioned reasons (protection and control), monitoring the DC or AC currents and voltages at the input and output of the inverter is needed. This is also essential for successful loop control. Again, depending on the regulation accuracy required, the choices for voltage and current transducers are various. Furthermore, auxiliary inverters are subject to cost pressures and often the least expensive measuring solutions are the final preferences. In this context, the best compromise of the price/performance ratio for the voltage measurement is the **LV 25-Voltage** family (200 V to 1200 V) and for current measurements, models derived from the **LTC** and **LAC** families are typically the best solutions. All use the Closed Loop Hall effect technology providing high bandwidth, overall accuracy at + 25°C between 0.4 and 0.8 % of nominal current (or voltage) and fast response time for current

On-Board Applications

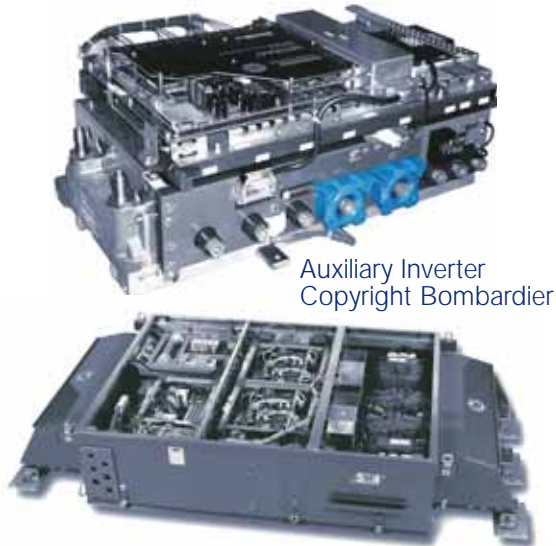

Auxiliary Inverter
Copyright Bombardier

SMA Technologie AG



Copyright ALSTOM

LF FAMILY

Very compact packages

2000 A

1000 A

500 A

300 A

200 A

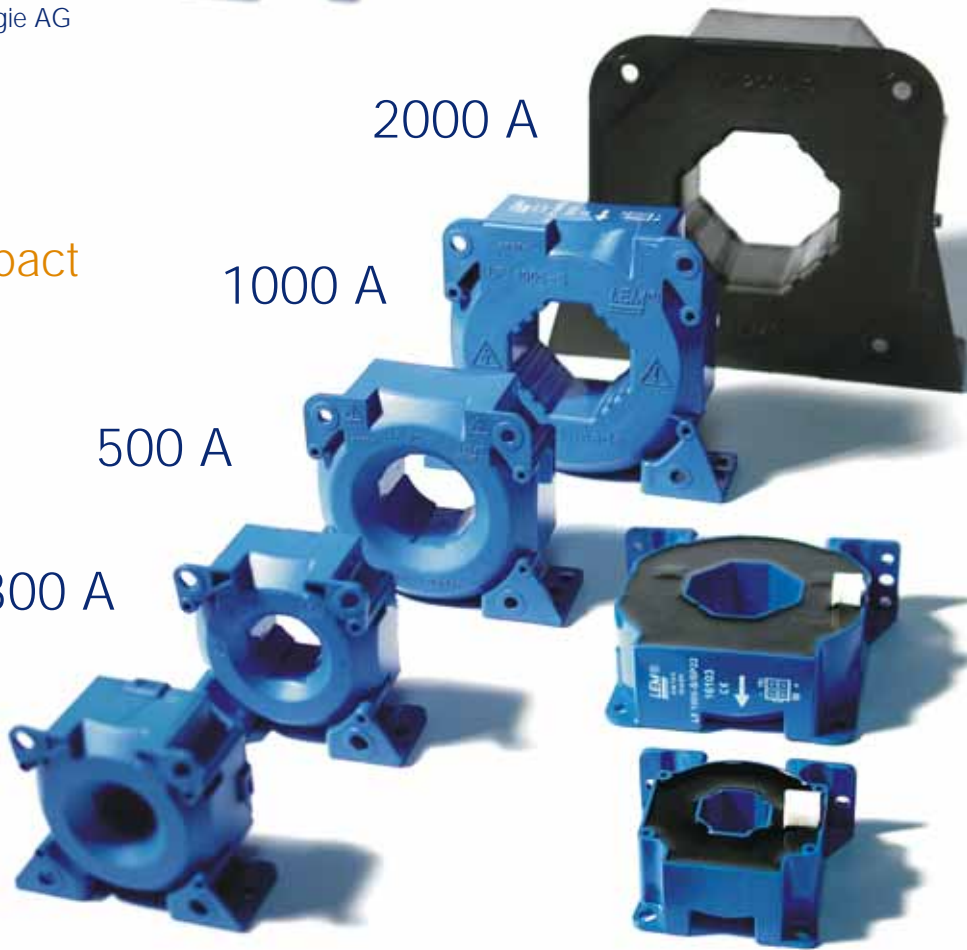

LAC 300-S



Mounting versatility

Several horizontal or vertical Mountings

transducers (less than 1 μ s @ 90 % of I_{pn}).

If mounting constraints or overall dimensions restrictions are relevant then other models can be used for this function, such as the **LA 205 / 305** series or **LT** and **LF 505 / 1005 / 2005-S** families for example.

However, if the price is the main issue and if overall accuracy of 1 % of I_{pn} at +25°C, a slightly longer response time (between 3 and 10 μ s @ 90 % of I_{pn}) and a shorter bandwidth (10 to 50 kHz) are acceptable in the application then, the solution might be an Open Loop Hall effect based current transducer: the **HTA**, **HAR** or **HTC** series.

2. Rolling Stock Light Rail Cars (Trolleybus/Tramways)

In principle, there is no major difference between the diagrams of heavy traction and light rail traction systems.

Both are mainly propelled by asynchronous motors.

As for the heavy traction, the chopper technology is still often used to supply a series DC current traction motor.

They operate mainly from DC voltages supplied by the catenaries with typical values such as: 600 V, 750 V, 900 V, 1200 V or 1500 V at the maximum

The main transformer and rectifier are then not needed.

Auxiliary inverters are also used, as for the heavy traction, to generate either three phase AC 380 V voltage or DC voltage (24, 48 V or more) for battery chargers. Both voltages (DC and AC three phase output voltages) can be isolated from the auxiliary inverter with an intermediate transformer.

Trolleybuses as well as tramways are becoming more and more important in cities to reduce the local air pollution. Trolleybuses are however more abundant than tramways, as they require less

significant infrastructure and also, as they are more convenient for steep grades (where tramways are not possible).

Often combined with a diesel engine (bi-mode), the rail network can be extended outside cities by using the diesel mode. Also, the trolleybuses and tramways, with their batteries charged via the auxiliary inverter or through wheel inertia or "Sup Cap," ensure their electrical propulsion in places where electrical networks are not possible for architectural reasons for example: High flexibility.

3. Rolling Stock Underground (Subways)

At one time, subways propulsion systems were based on resistor control to control a series DC current traction motor then, chopper control was progressively introduced in the 70's to reduce the power losses and finally, combined with the regenerative braking to reduce overheating in tunnels and to save energy. Most of the recent deliveries are now based on inverters controlling asynchronous motors.

They operate mainly from DC voltages supplied by the rails (third rail or 2 lateral rails) or by a catenary (for suburban lines) with typical values: 600 V, 750 V up to 1500 V at the maximum.

Subway systems also use auxiliary inverters for auxiliary functions such as ventilation, air-conditioning, doors openers, etc., similar to heavy traction, trolleybuses and tramways.

4. Rolling Stock Heavy Traction Diesel-Electric :

In the past, locomotives operating where no electrical networks exist had only a couple of options:

The diesel engine drives:

1. DC current generator,
2. or, a three phase alternating-current generator.

Both scenarios need to supply power to DC motors for the propulsion.

The three phase alternating-current generator must use a rectifier at the output to convert back to DC.

Current control from the generators is accomplished by a rheostat or a group of contactors.

Traction power is controlled by adjusting the rotational speed setting of the diesel engine.

DC voltages generated can be from 400 to 1500 V with currents from 500 A to 2500 A DC.

But as for all the other rolling stock, the trend is asynchronous motors. Today, we see that the share is 80 % with AC and 20 % DC.

This trend can also be justified by the requirement to reduce the fuel consumption.

Indeed, asynchronous motors provide better yield than DC in the same application.

The whole electrical system is similar to the one used for the heavy traction except that the initial AC power is generated by the AC generator (alternator).

The needs in current and voltage measurements are the same as previously detailed in the other rolling stocks.





Auxiliary Inverter



Copyright ALSTOM



Copyright ALSTOM

Large current range capability up to 4000 A

LT FAMILY

Large choice of secondary connections

Busbar or aperture

LA 205 / 305 FAMILY

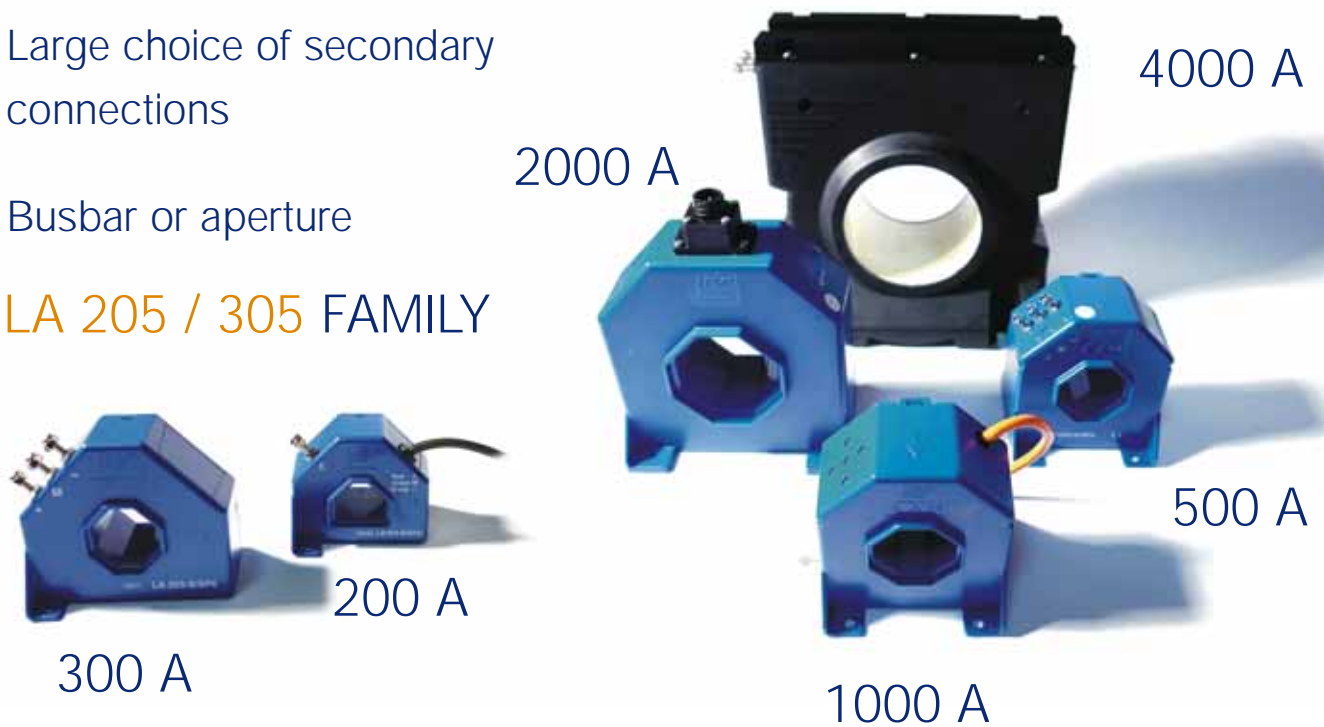

300 A

200 A

1000 A

500 A

2000 A

4000 A

Substations

Most of the trains are powered electrically. The necessary power to energize the electrical motors for locomotive propulsion is generated at the railway substations.

Power substations convert the high voltage provided by the utility company's distribution lines to the low voltage (AC or DC) and supply it with direct current needed to operate railway vehicles.

Once generated, the voltage and current are distributed to the locomotives or rolling stocks via the catenaries or rails (for urban underground railway for example). The voltages generated by the substations are various, due to the different possible voltage networks existing, according to the country where the rolling stocks are running. All the following voltage networks exist in Europe:

- 1.5 kV DC : in south of France, Netherlands...
- 3 kV DC : in Spain, Italia, Latvia, Slovenia, Estonia, Poland, Belgium, Croatia, Moldavia... representing about 30 % of the worldwide railway electrical lines,
- 15 kV / AC / 16.7 Hz: in Germany, Switzerland, Austria, Norway, Sweden...
- 25 kV/AC/50 Hz : Portugal, North of France, North of UK, Finland, Belarus, Yugoslavia, Bosnia & Herzegovina, Macedonia, Greece, Romania, Bulgaria, Hungary, Lithuania, Denmark...
- 3 kV DC and 25 kV/AC/50 Hz : Czech Republic, Slovakia, Ukraine, Russia...
- 750 V DC : UK...

Today, the trend is to have more and more heavy rolling stocks powered with voltage lines under AC voltage.

For the subways, trolleybuses, or tramways the voltage line is typically between 600 to 900 V DC (600, 750 and 900 Volt).

The substations then supply these various voltages to the rolling stocks.

The supplied voltage type (AC or DC) and levels make the substations different in their building.

These substations are located as close as possible to the tracks to maintain a consistent power level. The number of substations all along the track is dependent on the power supply requirement (subway or high speed trains for example) and also of the traffic.

Generally, they are made up of (figure 6):

- AC switchgear,
- Power transformers,
- Power rectifiers,
- DC switchgear.

Initially, the substation has an input voltage of 10.5 kV/AC/50 (60) Hz up to 66 kV/AC/50 (60)Hz, as an example, and can convert it into different levels of AC or DC voltages depending on the network supply requirement.

transformers may have additional windings for metering and protection purposes.

Some relays are protecting the transformer and also contribute to the rectifier protection.

Rectifiers

Most of the rectifiers are in 3-phase bridge connection.

These rectifiers shall withstand a full short circuit until the opening of the AC breakers; this is rather common in traction networks.

It is not unusual to find current transducers measuring earth leakage current from the rectifier to the rail (as represented in figure 6).

DC switchgear

DC switchgear is used to connect the rectifier DC busbar and the catenary (DC line).

Its aim is to open the circuit:

- During low impedance short circuits, the DC switchgear must

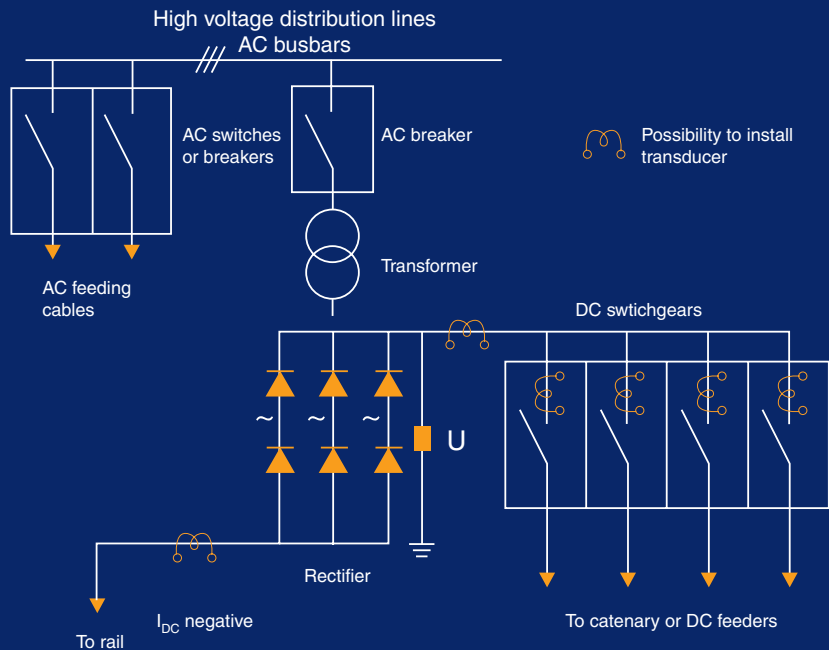

Figure 6: Typical Substation layout.

AC switchgear and Power transformers

AC switchgear is similar to the ones installed in AC distribution stations. In a general way, the AC current

open within milliseconds to prevent overcurrent levels exceeding breaking capacity.

You will find current transducers accurately measuring and monitoring these short circuit



Copyright ALSTOM

HAR 1000-S

Small size for 1000 A measured



LV 100-VOLTAGE

Voltage Measurement
from 50 to 4200 V

overcurrents while feeding relays with defined trigger levels to open the switchgear without delay (as represented figure 6).

- During medium to high impedance short circuits, the DC switchgear must open within a few hundred milliseconds. Again, the combination of the current transducer and relay will trigger the switchgear to open, however, electronic analysis of the transducer output waveform would allow further consideration and decision making (as represented figure 6).

Typical nominal currents in DC switchgear range from 1000 to 10000 A DC and voltages from 600 to 3000 VDC.

Current transducers **LT 4000-S/SP32, SP13, SP34, LT 4000-T/SP42**, or **HAZ 4000...20000** models can measure and detect these required levels and are especially useful due to their large apertures allowing wide primary conductors as this is often the case in this kind of application.

The protection can also be ensured by measuring the current at the rectifier output using the same current transducers previously indicated., and represented in figure 6.

The voltage at the DC switchgear or the DC busbar (rectifier output) is often monitored to ensure the right voltage supplied to the catenary (The **LV 100-4000/SP2** is a possible voltage transducer solution as represented figure 6.

Many times, when DC circuit breakers interrupt the circuit, a reverse voltage is generated at about 2 times higher than its nominal value. This reverse voltage is generated by the arc splitting process. This arc is split into small arcs in series within the arc chute and each individual arc generates a reverse voltage (20 to 25 V). These small arcs are contained between arc splitting plates. The sum of all these individual small

voltages makes the total reverse voltage.

After the interrupt (up to 80 to 150 kA peak), the current then decreases with a time constant L/R while the breaker reverse voltage is higher than the busbar DC voltage. The arc stops when the current is at a zero value.

The current transducers installed must support these high overcurrents (representing sometimes 20 times their nominal value) and voltages.

When bare or semi-isolated busbars are used for the primary current feed into the substations, then the isolation for transducers is required (12 kV_{RMS}/50 Hz/1 min as isolation test voltage as an example).

On the other hand, if the primary conductor is isolated, this will typically result in a large conductor requiring current transducers with a large aperture. The **LT 4000-S** and **HAZ** models provide the oversized aperture for large isolated primary conductors.

HAZ models are designed for various nominal current measurements from 4000 up to 20000 A and can supply various output signals such as :

- +/- 10 Volt instantaneous: **HAZ xxxxx-SB** models,
- +/- 20 mA instantaneous: **HAZ xxxxx-SBI** models,
- + 4 to + 20 mA instantaneous: **HAZ xxxxx-SBI/SP1** models,
- + 20 mA DC TRUE RMS: **HAZ xxxxx-SRI** models,
- + 4 to + 20 mA DC TRUE RMS: **HAZ xxxxx-SRI/SP1** models,
- + 10 Volt DC TRUE RMS: **HAZ xxxxx-SRU** models.

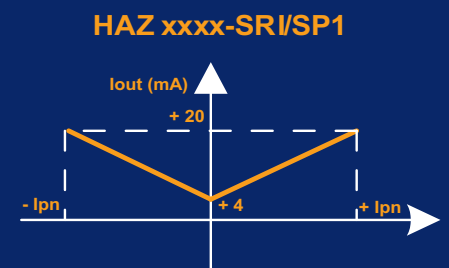
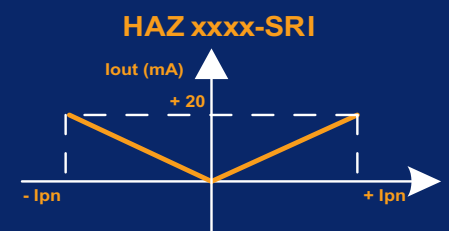
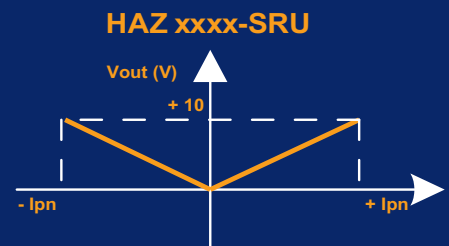
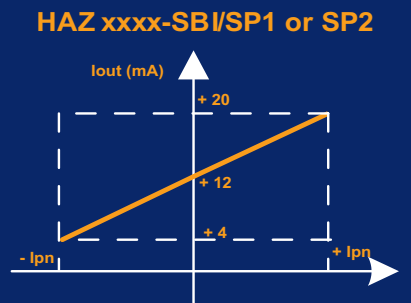
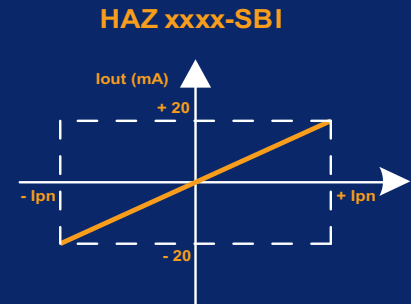
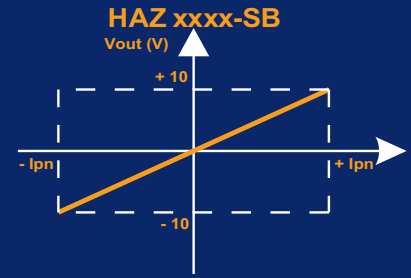

HAZ 4000 ... 20000 FAMILY

Signal Conditioning or Instantaneous Output

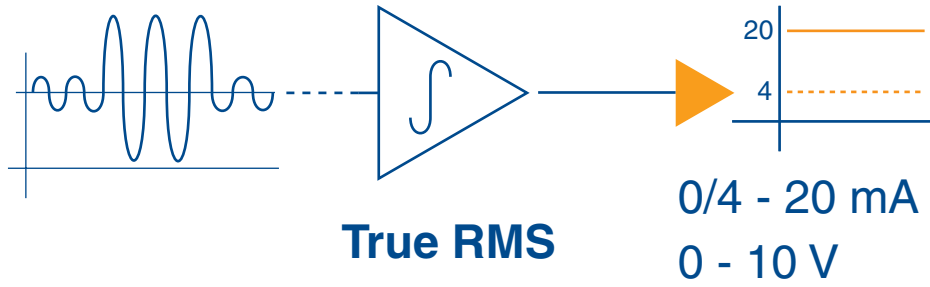

Output \ Model	Instantaneous	DC True RMS
Voltage 0 - 10 Volt	- SB	- SRU
Current 0 - 20 mA	- SBI	- SRI
Current 4 - 20 mA	- SBI / SP1 or SP2	- SRI / SP1

Measurement from 4000 A to 20000 A_{RMS}

with the same compact size



Energy Measurement for On-Board Applications: EM4T

With the liberalization and/or privatization of some of the major rail networks, a need arose to use both the existing and planned rail networks under construction to run traction units across national boundaries.

This gave train designers the daunting task to develop multi-system locomotives to be used on multi-networks.

These prime movers would be needed to operate on the different supply networks of bordering countries along the route without requiring an equipment exchange at the regional or network supply border.

Today, it is therefore technically possible to transfer people or goods throughout Europe, from Norway to Sicily for example, without any physical exchange of the locomotive (Picture 1).

Changes also in the Energy Markets in the form of deregulation and increased competition for large user contracts brought potential benefits for those willing to negotiate for their electrical traction supply requirements.

This negotiation however requires greater knowledge and understanding of the load profile of bulk supply points in one of the harshest electrical environments – the traction supply.

Also to date, any financial benefits to the train operating company of regenerative braking - energy fed back to the supply network when a train is generating power under braking conditions- was only able to be determined based on un-metered experience.

With the new energy meter from LEM, for the first time, data for the precise calculation of both supplied and regenerated energy for billing purposes can be accomplished on the train, independently of the energy supplier.

The first universal energy meter for traction especially designed for on-board applications

With the **EM4T energy meter**, LEM has introduced the first universal energy meter for electric traction units with approval for billings in some countries (e.g. in Germany from the Physikalisch-Technische Bundesanstalt (PTB)). Thanks to the advanced capability of the **EM4T**, it can be used both in new multi-system locomotives now under construction and for retrofitting to all types of electrical rail vehicles already in operation.

EM4T - the load profile provider

EM4T is a single-phase energy meter and compliant to all relevant standards for metering and on-board use. The energy values are collected and stored in load profiles which can be set and stored in intervals of 60 minutes to 1 minute. The measured data recordings contain the following details:

- Date and time stamp
- Events
- Train identification numbers
- Absolute energy values for consumption and feedback of active and reactive energy
- Frequency of the network (50Hz, 16.7Hz or DC).

Data transmission for the meter readout is possible via isolated, serial interfaces or via an optical interface according to EN 61107, mounted on the front panel. An external time base (e.g. GPS) can be used at one of the serial interfaces for periodic time synchronization. The memory incorporated in the device enables recordings of the above data over a period typically of more than 300 days (at a load profile of 15 minutes).

Meter accuracy of the EM4T

The meters are offered with a standard class accuracy of 1%. Since even small inaccuracies can

cause large errors in the case of calculating and invoicing such large energy quantities, **EM4T** is also available with improved accuracy options at class 0.5% and 0.2% (according to EN 62052-11).

Technical details

The input variables - current and voltage - are connected to the measuring circuits of the **EM4T** via differential inputs (Picture 2 and 3), designed for connection of all current and voltage transducers/transformers currently available on the market.

Four (4) input channels are proposed for metering of both DC and AC signals of any existing traction network (600 V DC to 3 kV DC, 15 kV AC 16.7 Hz, 25 kV AC 50 Hz).

The requirements for current measurement at this level can be diverse. A clamp-on current transducer can be helpful in the application so as to not disrupt the installation. This is the case with LEM's **LA 200** or **500-SD** models.

Or, a large aperture transducer is appropriate when the primary conductor is highly isolated to support the high level of voltage (15 to 25 kV AC as nominal level): LEM's **LT 4000-S** transducer family is of this category.

For the DC networks, the transducer's inherent isolation properties are adequate.

Analog to Digital Sigma-Delta conversion processors suppress high frequency disturbances in both channels, enhancing even further the capacity to handle the often rapid supply transitions within traction supplies.

The 16-bit microprocessor reads the sampled values and calculates the real energy in adjustable intervals (standard value = 15 min). The results are then saved in flash memory (a special variant of an EEPROM).

The voltage supply is via a DC/DC converter, which in the standard version, is designed for a nominal voltage of 110 V DC (77 to 143 V).

Picture 1 :
European rail networks



- not electrified
- electrified (DC) tracks
- 1.5 kV DC
- 3 kV DC
- 15 kV 16.7 Hz
- 25 kV 50 Hz
- 3 kV DC / 25 kV 50Hz



Siemens Train



EM4T

Energy meter for
electrical traction
units railways

Energy Measurement

A version with a nominal voltage of 24 V (19.2 to 31.2 V) is also available as an option.

Standards and regulations

The EM4T has been designed to comply with the following standards:

- EN 62052-11
- EN 62053-21:
Class 1, 0.5, and 0.2 alternating-current watt-hour meters
- EN 50155:
Electronic equipment used on rolling stock
- EN 50121-3-2:
EMC part 3-2: Rolling stock - Apparatus
- EN 50125-1:
Environmental conditions for equipment part 1: Equipment on board rolling stock
- Final draft (Issue 5) of the CENELEC-TC9X working group 11 (Railway Applications – Energy metering on-board trains)
- CENELEC prEN 50463: 2005

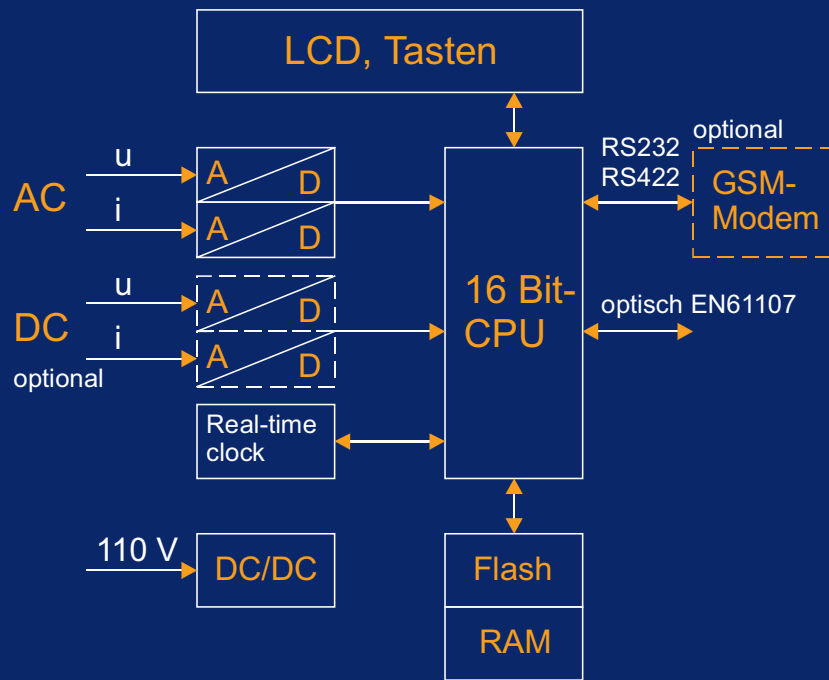

Picture 3: Block diagram of the LEM energy meter



CV 4-VOLTAGE FAMILY

High accuracy

Large bandwidth

1000 V to 4200 V



AV 100-VOLTAGE FAMILY

50 V to 2000 V

Short response time

One unique design

Energy Measurement

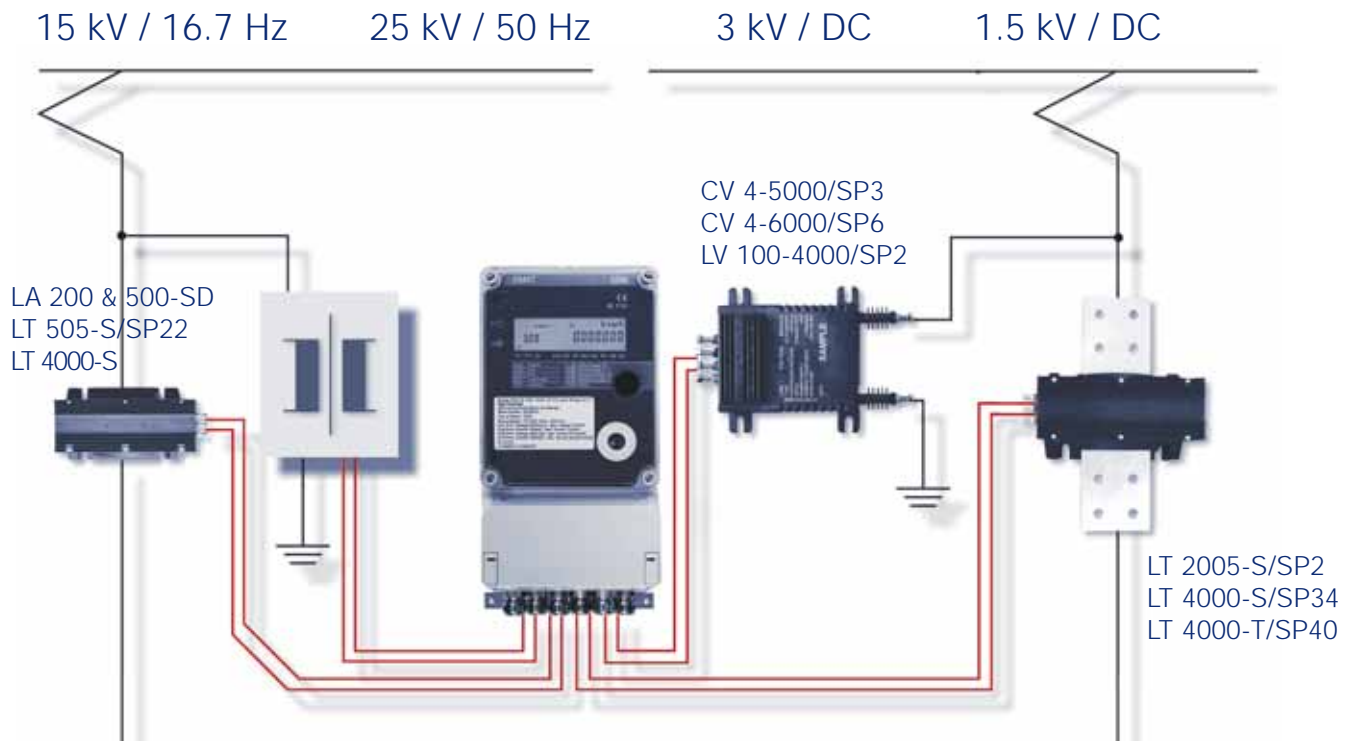

Part of a high voltage frame of a multi-system locomotive with the positions needed for current & voltage measurement

LA 200 & 500-SD FAMILY

Clip-on current transducers
Easy installations around
cables and busbars

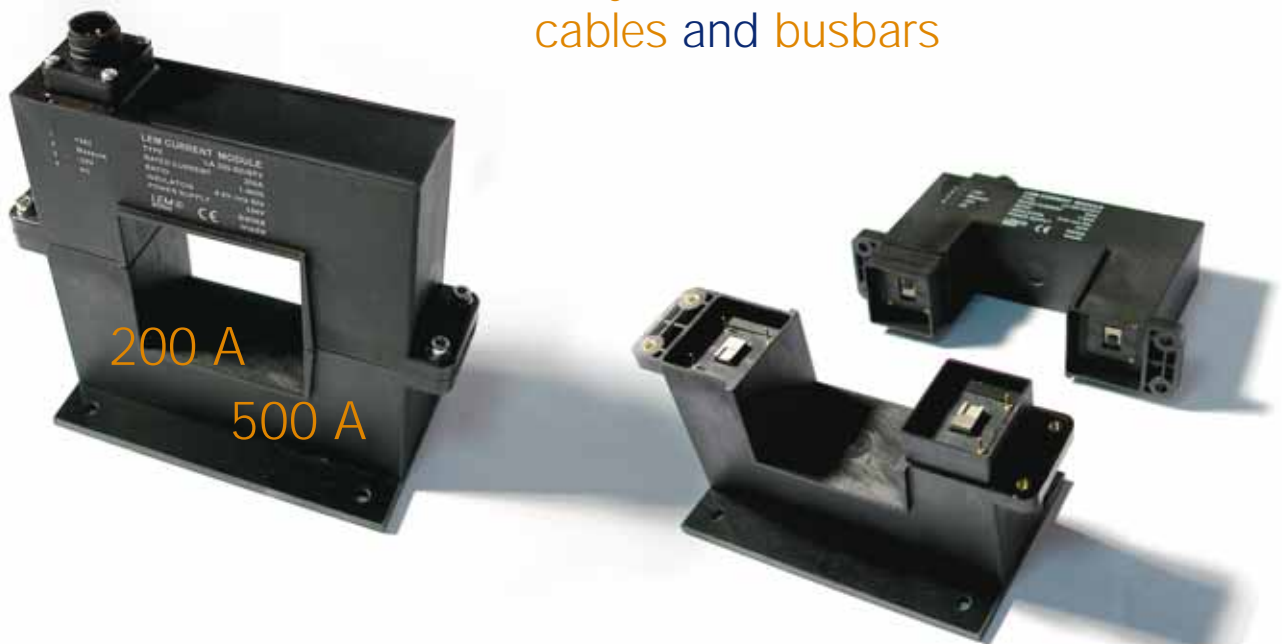

Specific Railway Applications

1. Interference Frequencies Detection

Most of the trolleybuses, trams, subways and suburban networks work with DC voltage (600 to 3000 V DC).

These networks are divided into different isolated sections, each powered by different substations as seen previously.

In addition to their normal DC voltages provided, these substations are supplying also a small AC signal (of 42 and 50 Hz or 60 or 100 Hz).

When a train enters a given section of the track system, the wheels short the AC signals (through the axle) and the "Track-Free-Signaling-System" protects this area with a red stop signal for the other trains.

By using PWM (Pulse Width Modulation) converters, the drive system of the trains also generate low frequency signals which are fed back into the network.

Due to these generated interference currents, the frequency spectrum must be controlled and limited to 10 A maximum through internal filters, because when a frequency of 42 Hz and/or 50-60-100 Hz is fed into the network, the "Track-Free-Signaling-System" will measure the signal and will open this section of the track for the other trains.

For example, in an application, the 25 Hz current generated and sent back to the DC supply can be 50 times greater than the maximum limit tolerated at 42 or 50 Hz (0.5 A).

LEM RA family current transducers have been designed to detect AC currents up to 20 A peak, in a dedicated bandwidth, superimposed on a DC current of 2000 up to 3000 A DC with a given accuracy.

A control system is then used to

monitor the output signal of the LEM transducer. If frequencies of 42 Hz and/or 50 - 60 - 100 Hz are present, the system detects them and automated equipment stops the train.

Normally, the PWM converters are designed so that the drive system cannot generate these frequencies, but these may appear because of defects in the internal filter, malfunctioning of the pulse modulation system of the drive, etc.

The RA products are considered as important products in this application as ensuring a safety function.

That is why the RA transducer is used in a redundant way, with 2 pieces on the same busbar. Some additional functions are often required in this kind of application and then added, like an built-in test winding, part of the simulation system to check the overall safety chain before every start of the train.

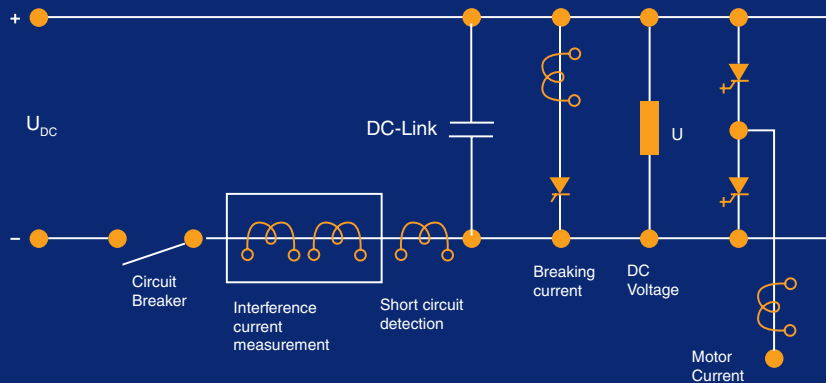

Figure 7: Interference current measurement on the DC link.

2. Main Transformer Saturation Detection

The measurement of a low DC component in high AC currents can be requested to control the current supplied by the main transformer previously to the driving converter. This DC component can saturate the transformer and, as a result, has to be limited or the faulty converter disconnected.

A 2000 A_{RMS} transducer is required to measure both the AC current and the DC component. For that application, a 1 A accuracy for the

DC component measurement is sufficient and is performed by a Closed Loop Hall effect transducer. However, to achieve this level of accuracy, and withstand a high parasitic magnetic field environment, a special design is necessary (LEM current transducer LB 2000-S/SP4 for example). Recall that the standard 2000 A transducers have a DC offset error of at least 2.5 to 3 A (Figure 8).

If the DC component control is made on the primary of the transformer where the supply voltage can be of 25 kV_{RMS} AC, the AC current level will be much lower and the low DC component allowed will then require a more precise current measurement technology. Typically, Fluxgate technology can be used for that requirement but that means also a transducer with a large aperture as the primary conductor will have to

be isolated for the network voltage (25 kV for example) or the transducer proposed will have to support this voltage level constraint.

3. Fault Detection

In underground DC traction power supplies using a positive and a negative running rail, differential current detectors (CD differential current transducers) are needed to detect faults from either supply pole to earth (Figure 9).

Such faults would perturbing currents for the signaling system. In this application, primary currents reaching up to 1200 A are

controlled with a detection of an imbalance level of 1 A at a precision of 0.1 A.

In the same kind of underground vehicle, the heating circuits must also be controlled with differential current transducers. Currents of approximately 100 A are monitored for imbalance down to 100 mA with a maximum offset error of 15 mA.

4. MES Solutions

For the measurements of currents, voltages and powers, LEM can design customer-tailored complete solutions.

These are, for example, several transducers mounted on one printed circuit board and delivered as a wired and tested set. These are the MES reference types.

As an example, the MES 14 :

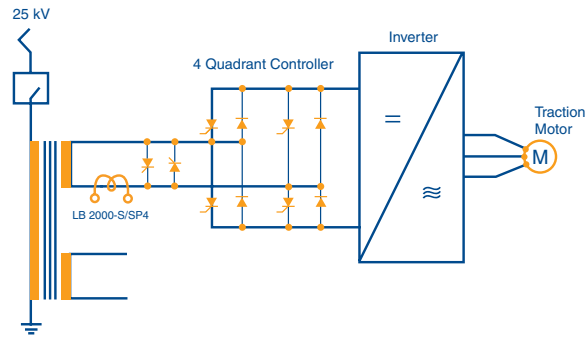

Figure 8: AC+DC measurement in transformer output of driving converter

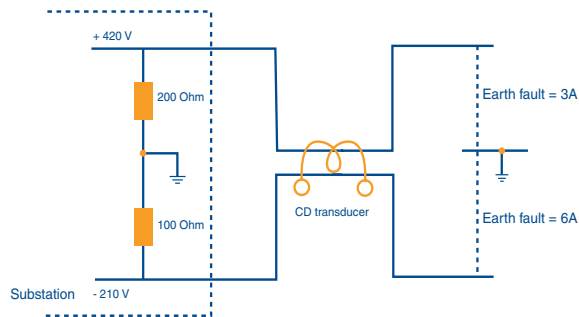

Figure 9: Current balance detector for underground



CD FAMILY



LB 2000 FAMILY



Copyright ALSTOM

RA FAMILY

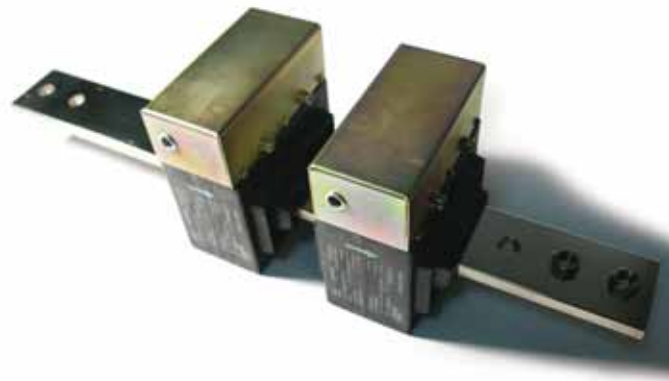

Mining Trucks Applications

Mining Trucks Traction

Off-highway vehicles (trucks) operating in mining use high horsepower diesel engines combined with an electrical drive system to propel them efficiently with electrical motors in harsh environments such as large surface mining.

AC or DC drive systems can be used according to the motors used. The global systems for propulsion of these trucks are quite similar to the ones used for the Diesel-Electric railway locomotives.

LEM, based on its experience in traction applications, supplies current and voltage transducers for control in inverters, one of the major sub-systems in truck drive systems. In open cast mining (surface mining), the conditions are extreme leading to high constraints.

The truck wheels are electrically motorized, either DC or AC motors, driven by a specific drive (or inverter), as the ones used in traction applications to ensure the propulsion locomotives.

Electronic drives systems, compared to mechanical drives, provide lower operating costs and higher haul productivity.

The elimination of torque converters, drive shafts, transmissions, and differentials (all exhibiting high wearing coefficients), reduces the maintenance, improves the trucks life time, reliability and finally overall cost.

The motor torque and speed applied to the wheels is controlled by the DC or AC drives by closely monitoring the voltage and current supplied, avoiding then a gear box. This provides smooth application of the power to the wheels (this also reduces tire wear during wheel spinning and safe operation).

Wheel drive system with DC motors

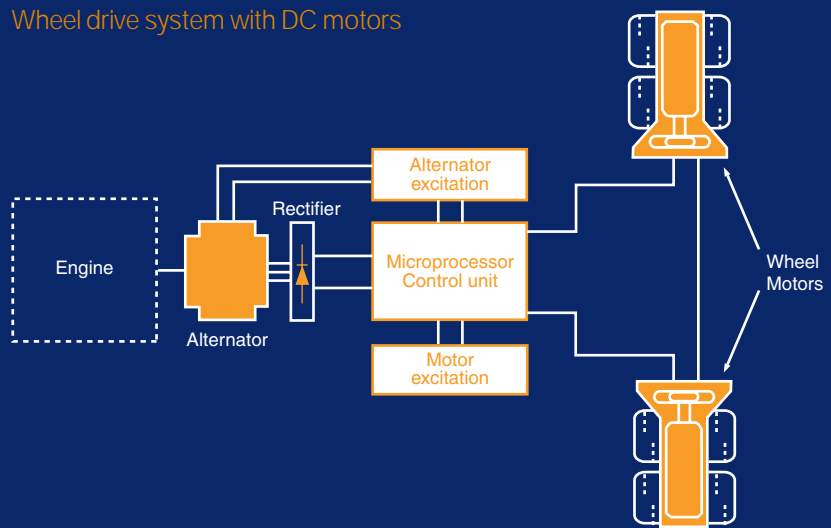

To simplify, the system is made up of:

- An alternator,
- a rectifier,
- a microprocessor control unit,
- and motorized wheels (DC motors).

The microprocessor control unit monitors the alternator and rectifier, and DC motorized wheels to deliver optimal performance.

The use of a microprocessor control unit allows quick diagnostics when defects occur.

mining) and provide the whole system enhanced productivity by reducing maintenance services (Brushes elimination, contactors decreasing...).

The use of power electronics makes the system simpler and more reliable with increased efficiency. And the improved efficiency leads to less fuel consumption.

To simplify, the AC system is made up of:

- An alternator,
- a rectifier,

Wheel drive system with AC motors

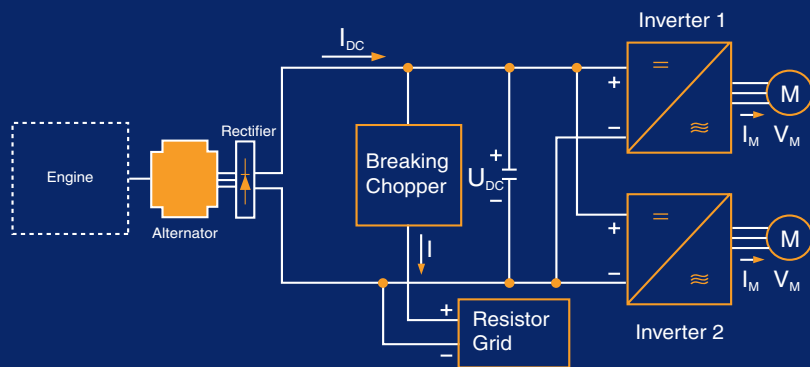

As for the traction propulsion in railway industry, the trend today is to use IGBT (GTO are also still used) based AC drive systems to control AC motors (generally asynchronous motors driving the wheels) for new levels of performance. AC motors are indeed less restricting (smaller, more robust, and, better suited for harsh environments such as surface

- a DC link,
- one or several DC/AC drive inverters,
- a microprocessor control unit,
- and motorized wheels (asynchronous motors).

The drive inverters are controlled by the microprocessor control unit to convert DC to AC power and to

Mining Trucks Applications

the desired power (PWM voltage inverter with variable frequency, AC current). This is the same concept used for the drive propulsion inverters for locomotives in railway industry. All of the inverter output parameters (current, voltage, frequency) are controlled by the microprocessor control unit, adjusting if necessary, certain parameters at the inverter leading to attain the required power for the commanded torque and speed of the wheels.

Current and voltage transducers are essential to monitor these parameters. Nevertheless, due to the harsh conditions of the application, the models used have to be well adapted. Mining trucks are exposed to extreme dust, humidity, and temperature conditions all around the world; therefore, the transducer must be designed to perform optimally in this environment.

The result can be models issued from the **HTC** series (500 to 3000 A nominal), **LT 505 - 1005 - 2005** series for current measurement and from **LV 100-Voltage** family for voltage measurement. All transducers are potted to guarantee exceptional protection against humidity and dust. Also, vibration immunity is important in such applications. This explains the choice of transducers adapted for traction applications, as they have already complied with high level vibration constraints originating from railway applications. Hence, all are qualified against the EN 50155 standard for the environmental tests.



Copyright ALSTOM

HTA FAMILY



250 A
1000 A

HTC FAMILY



500 A
3000 A

One unique design
to cover their ranges

Trackside Applications

The rail industry operates in a physically unique context. If there is a points failure, signal problem or a fault with the rails, you can't just drive around the obstacle. More and more, people and goods are to be moved. Existing infrastructure must be exploited more efficiently.

The increasing separation of infrastructure and railway undertakings responsibilities within the rail system, particularly in Europe, underlines the importance of trackside and on-board monitoring. They serve to optimize the capital and maintenance cost of track equipment and rolling stock while ensuring satisfactory levels of safety and operational performance.

A study about the reliability and maintainability of the rail infrastructure revealed the following needs :

- Introduction of condition monitoring methods,
- Optimization of the maintenance plans,
- Guarantee of the safety level.

Monitoring systems arose from these needs expressed by the various maintenance contractors. One of the goals was to decrease train service interruptions due to failures to improve the punctuality and to reduce potentially strong penalties.

Also, the availability of the railway network is becoming more and more crucial.

Existing infrastructure must be exploited more efficiently, that's why monitoring crucial track objects (points, crossing gates, signaling...) is an indispensable tool in this context. Online monitoring makes it possible to take preventive action. Replacements take place before abnormalities lead to failures.

Main functions of condition monitoring :

- Preventive maintenance, replacement to prevent failures,
- Maintenance process improvement.

About 25 % of disturbances causing trains delays are due to the point machines.

1. Points Machines (Picture 4) and Condition Monitoring

To measure the movement and the position of the switch machines, you can use a:

- Position transducer,
- Power transducer,
- Pressure transducer,
- Current and voltage transducers.

The curve of the motor current is shown every time the switch runs. This curve is compared with an ideal situation (reference curve) of the motor current.

A significant difference between the last curve and the reference curve will result in an alarm signal. Maintenance engineers can adjust the alarm level (Figure 10) and it is also possible to measure the voltage to adjust the trigger if there is a change in the voltage level.

As time elapses, changes in the machine footprint can indicate mechanical wear, lack of lubrication, points misalignment, and jamming within the points mechanism caused by ballast, electrical motor and winding failure. All indications result in an increase in total current absorbed.

Any variation from the normal profile also indicates the likelihood of other developing problems – wear, rust, debris, vandalism, etc.

An early warning of machine failure, using current profile monitoring before problems or critical breakdown occur, is provided to signal preventive maintenance.

When necessary, the replacement of material (points motor for example) is performed, with supporting evidence, i.e. current profile records.

The information is collected and

analyzed to predict a more preventive maintenance time for similar equipment.

Generally speaking, this optimizes the efficiency of the railway maintenance staff, minimizes the traffic disruption and keeps costs to an acceptable level.

LEM has designed a dedicated clip-on current transducer family called **PCM** (Points Condition Monitoring), covering DC or AC current measurements of 10, 20 and 30 A nominal. To be mounted directly in the switch and without disruption to existing cabling or connections, the **PCM** current transducer is to be secured around the conductor without any contact. This is one of the main requirements for retrofit applications. Its mechanical design is also adapted to the harsh environment along the tracks and waterproof versions are available.

Most of the motors used for the points machines have been DC motors but today, the trend is to use AC motors as they are more robust, compact and less expensive on maintenance.

The **PCM-PR** versions are dedicated for these AC motors to control the high speed train switches. They measure the AC low frequency currents (from 0.040 to 1 kHz) exactly for the same reasons as for the DC motors previously and provide a 4-20 mA DC output representing the true RMS value of the measured signal. This kind of output signal is compatible with PLCs that analyze the data.

PCM products are designed for use by the railway maintenance contractors as a retrofit tool for the actual infrastructure. Typically, the contractors provide current measurement without disruption to the operating points machines.

It is important not to interrupt the current carrying conductors to the points motors as this would disrupt the safety chain mechanism. Hence, the **PCM** transducers are designed to allow uninterrupted

way of the clip-on package. This type of retrofit is a requirement by the integrators and infrastructure owners.

Of course, condition monitoring using transducers may be integrated into the initial design of the points machine system. If this is the case, electrical current interruption is not a concern and therefore other, more cost effective, current measurements are available. Being part of the original electronic assembly, PCB mounted current transducers might be viable solutions. LEM can offer the **LTS 6-15-25-NP** or the **LA 25-NP** series transducers for this particular application.

2. Track Circuits (Picture 5) and Condition Monitoring

About 5 % of disturbances causing trains delays are due to track circuit failures.

The track circuit is a method of indicating the presence of a train on a given section of line. With relay-operated signals, the extend of the circuit typically corresponds to a signaling block section.

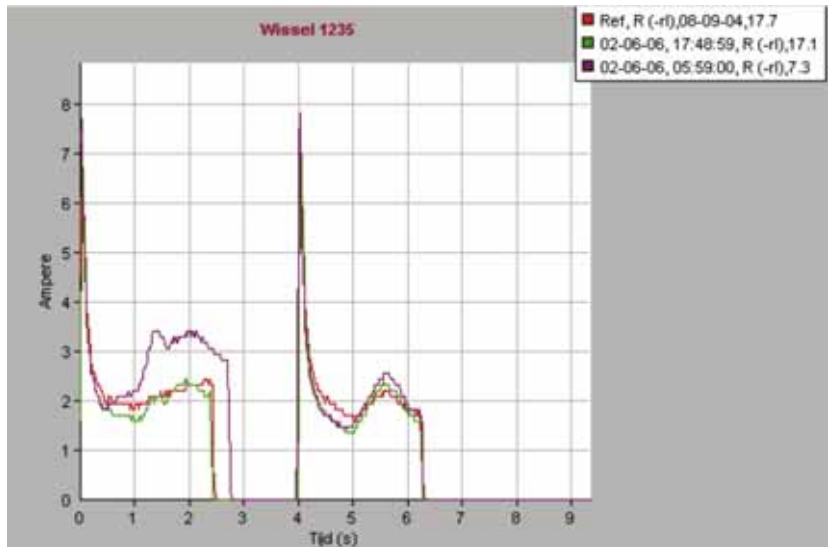

Figure 10: Typical current profile of a points DC Motor over the time
Picture provided by courtesy of STRUKTON

PCM FAMILY

10 to 30 A



Clip-on design - Ideal for retrofit applications



Picture 4: Points Machine along the tracks.

LTS FAMILY

6 - 15 - 25 A



LA 25-NP FAMILY

0.25 to 25 A



PCB mounted current transducers

The source of current begins at one end of the isolated rail section, the driving current travels down the rail to the end of the section where it then energizes a relay, is redirected to the other rail section and finally, returns to the power supply to complete the circuit. The energized relay prevents the signaling lights to operate indicating that the rail section is free. (Figure 11).

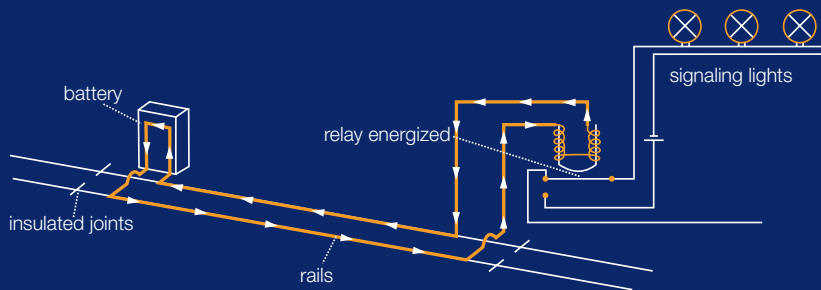

Figure 11: Track circuit situation with no train on the track.

However, if there is a train on the section, the current path is shorted through the wheels and axles, bypassing the relay, back to the other rail and returning to the power supply. The relay is now de-energized and the signaling lights are in operation indicating the presence of a train (Figure 12).

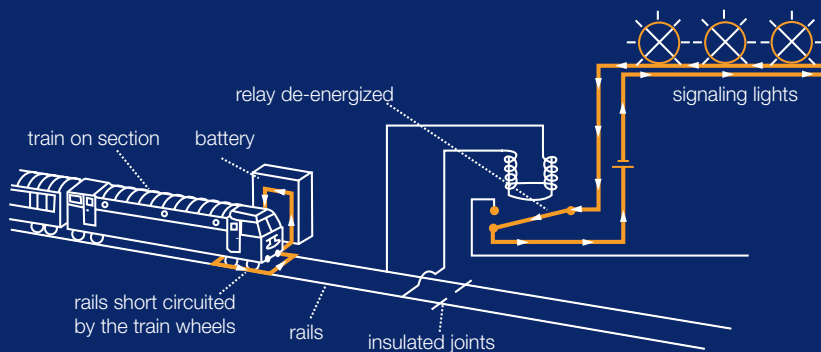

Figure 12: Track circuit situation with a train on the track

For the system to work reliably, rail joints have to be electrically bonded with a wire connecting the two rail ends. At each end of the section, the circuit has to be kept in isolation. Foreign objects (ice, leaves, etc.) on the line can cause failure of this circuit resulting in an avoidance or creation of an untimely short circuit.

This kind of circuit is typical for older and existing installations, however

today, with modern continuous welded rails, it is more and more difficult and less desirable to fit insulated joints. Today, coded electrical impulse track circuits are installed.

Monitoring the actual track circuit current flow, in lieu of the relay, would allow interpretation of the current levels as an indication of

potential problems as well as knowing when a train is passing or not. Typical current monitoring levels are between 20 and 90 mA depending of the resistance of the short circuit. A current threshold detector can be used to report relay failure when the circuit current changes but the relay

does not operate. By sensing the current in the lamps, the system can not only determine if the lamp filaments are intact and wired properly but, can also record the aspect (color) of the signal when a train passes a section of track. Consequently, an alarm can be issued if the driver passes a red signal. Monitoring of the supply voltages for both the track circuit and signal lamps will also highlight failures.

LEM transducers can work with AC or DC track circuits and are extensively used in the railway industry.

The **RCM 2A-VI/SP1** current transducer (0 to 2 A DC measuring range) has been specifically developed for measuring the current in the vast number of relays used within the rail network. In addition, this model design exhibits the non-contact measurement technique which is clearly a requirement for avoiding interference of relay operation.

For non-contact measurement, the **CT** series is also an option with nominal measurements of 100, 200 or 400 mA_{RMS} and a large aperture of 11 mm diameter.

Other current transducers are also available for this function, such as the **LTS 6-NP** or **LV 25-P** (6 A_{RMS} and 10 mA_{RMS} nominal, respectively) capable of measuring AC or DC waveforms with an integrated primary conductor.

3. Crossing gates (Picture 6) and Condition Monitoring

About +/-15 % of disturbances causing trains delays are due to crossing gate failures.

In the USA, priority is on the level crossings (railroad crossings). Each new level crossing uses current measurement for the motor, the incandescent lamps and bells.

The current measured may be DC as well as AC.

Although the future is LED lamp technology and thereby smaller currents, current measurement is still necessary for condition monitoring.

It is easily understood that the monitoring system must detect if the gate motor and signals are working properly when there is an approaching train. This is a question of safety and current measurement provides this knowledge.

The motor current waveform can be analyzed and compared with the typical current profile during gate activation.

Trackside Applications

An excess of supplied current to the motor could signify a potential failure or problem such as the end of life of the motor or an obstacle in front of the gate.

Signal monitoring is a method to identify if the lamps are working fine. The current provided to the LED lamp cluster is monitored by a highly accurate current transducer. A reduced LED current level would indicate that one or several individual LEDs have ruptured.

There is a defined number of allowable defective LEDs in a lamp and this can be determined from the current level and then the defective LEDs can be replaced to ensure the minimum safety. Current transducers provide this information.

This early warning detection is useful when scheduling routine maintenance thereby reducing the costs to schedule an unplanned repair run.

Typical current consumption for a lamp produced with several LEDs is 500 mA and 10 A for the gate motor when lifting or lowering.

An inexpensive transducer solution for motor current monitoring is the **LTS** series with nominal current measurements from 6 to 25 A_{RMS}. For signal monitoring, the **CT-P** series meets the requirement with 3 models covering accurate measurements from 100 mA_{RMS} up to 400 mA_{RMS}.

These transducers provide measurement with no contact with the conductor. In this type of application, it is important not to add any new items in the existing signaling circuit, that is to say, not to introduce a new potential disruption in the circuit. The non-contact measurement is a must as they are considered safety items.



Picture 5: Tracks network

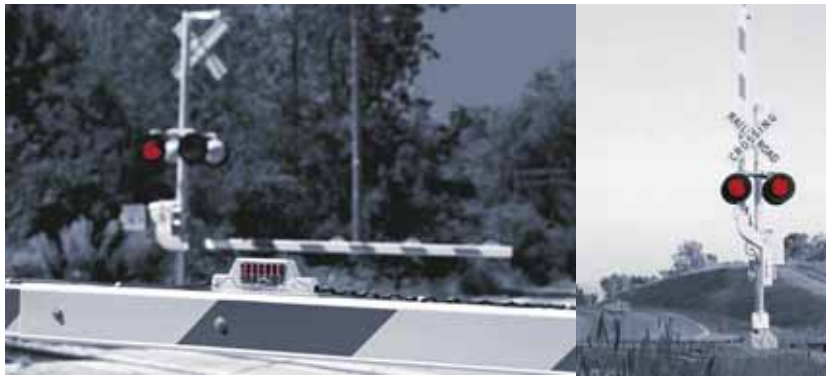

Picture 6: Signaling at a crossing gate

RCM FAMILY
DIN rail mounting



2 A

CT xx-P FAMILY
PCB mounting



0.1 / 0.2 / 0.4 A

Non-contact small current measurement

LV 25-P FAMILY



Current measurement of 10 mA_{RMS}

LEM's Quality & Standards

Quality is demanded by everyone and it is quite justified.

The levels of quality required by customers are different depending on the application as well as the standards to comply with.

This quality has to be reached but also maintained and constantly improved for both products and services. The different LEM design and production centers around the world are either ISO TS 16949, ISO 9001 and/or ISO 14001 certified.

Several quality tools have been implemented at LEM to assess and analyze its performances. LEM utilizes this information to take the necessary corrective actions to remain a responsive player in the market.

Among which the most representatives are:

DPT FMEA (Design, Process & Tool Failure Mode Effect Analysis) tool used preventively to:

- identify the risks and the root causes related to the product, the process or the machinery and,
- set up the corrective actions,

Control Plan: Description of checks and monitoring actions executed along the production process,

Cpk – R&R (Capability for Processes & Measurement Systems):

- **Cpk:** Statistical tool used to evaluate the ability of a production procedure to remain stable and accurate within a specified allowance range,
- **R&R:** Repeatability and Reproducibility: Tool to monitor the accuracy of a measurement device within a pre-determined allowance range,

QOS – 8D (Quality Operating System – Eight Disciplines):

- **8D:** Problem solving process used to identify and eliminate the recurrence of quality problems,
- **QOS:** System used to solve problems,

IPO (Interactive Purchase Questionnaire): Tool aimed at involving the supplier in the quality of the purchased parts and spare parts.

In addition to these quality programs, and since 2002, LEM embraces **Six Sigma** as its methodology in pursuit of business excellence. The main goal is to create an environment in which anything less than **Six Sigma** quality is unacceptable.

LEM's Standards

LEM traction transducers are designed and tested according to recognized worldwide standards.

The EN 50155 standard dedicated to "Electronic Equipment used on Rolling stock" in railway applications is our standard of reference for electrical, environmental and mechanical parameters.

It guarantees the overall performances of our products in railway environments.

All of the LEM traction products are designed according to the EN 50155 standard.

CE marking is a guarantee that the product complies with the European EMC directive 89/336/EEC and low voltage directive and therefore warrants the electro-magnetic compatibility of the transducers.

UL is used as a reference to define the flammability of the materials (UL94V0) as well as the NFF 16101 and 16102 standards for the fire/smoke materials classification.

LEM is currently UL recognized for main models.

You can consult the UL website to get the updated list of recognized models at www.UL.com.

The individual datasheets precisely specify the applicable standards, approvals and recognitions for individual products.

The EN 50124-1 ("Basic requirements – Clearances and creepage distances for all electrical and electronic equipment") standard is used as reference to design the creepage and clearance distances for the transducers versus the needed insulation levels (rated insulation voltage) and the conditions of use.

The rated insulation voltage level allowed by a transducer intended to be used in an application classified as being "Railway", is defined according to several criteria listed under the EN 50124-1 standard. Some criteria are dependent on the transducer itself when the others are linked to the application.

These criteria are the following:

- Clearance distance (the shortest distance in air between two conductive parts),
- Creepage distance (the shortest distance along the surface of the insulating material between two conductive parts),
- Pollution degree (application specific - this is a way to classify the micro-environmental conditions having effect on the insulation),
- Overvoltage category (application specific - characterizes the exposure of the equipment to overvoltages),
- Comparative Tracking Index (CTI linked to the kind of material used for the insulated material) leading to a classification over different Insulating Material groups,
- Simple (Basic) or Reinforced isolation need.

LEM follows this thought process for the transducer designs:
 Example: LTC 600-S, current transducer in an propulsion inverter

Conditions of use:

Creepage distance: 66.70 mm,
 Clearance distance: 45.90 mm,
 CTI: 600 V (group I),
 Overvoltage category: II,
 Pollution Degree: 3.

Basic or Single insulation:

According to EN 50124-1 standard: With clearance distance of 45.90 mm and PD3, U_{Ni} (Rated impulse voltage) = 30 kV.

With $U_{Ni} = 30$ kV & OV II, the rated insulation voltage (AC or DC) called " U_{Nm} " can be from ≥ 6.5 up to < 8.3 kV.

With a creepage distance of 66.70 mm and PD3 and CTI of 600 V (group I), it is allowed to have 12.5 mm/kV, leading to a possible rated insulation voltage U_{Nm} of 5.336 kV. In conclusion, the possible rated insulation voltage, U_{Nm} in these conditions of use, is of 5.336 kV (the lowest value given by the both results from the creepage and clearance distances).

Reinforced insulation:

Let's look for the reinforced insulation for the same creepage and clearance distances as previously defined:

When dimensioning reinforced insulation, from the clearance distance point of view, the rated impulse voltage, U_{Ni} , shall be 160% of the rated impulse voltage required for basic insulation.

The clearance distance of 45.90 mm is already designed and then, we look for the reinforced insulation with this distance.

Reinforced $U_{Ni} = 30$ kV obtained with the clearance distance of 45.90 mm.

Basic $U_{Ni} = \text{Reinforced } U_{Ni} / 1.6 = 18.75$ kV.

Reinforced U_{Nm} : From ≥ 3.7 up to < 4.8 kV, according to the clearance

distance.

From the creepage distance point of view, when dimensioning reinforced insulation, the rated insulation voltage U_{Nm} shall be two times the rated insulation voltage required for the basic insulation.

With a creepage distance of 66.70 mm and PD3 and CTI of 600 V (group I), it is then allowed to have 25 mm/kV (2×12.5) vs. 12.5 mm/kV previously (for basic insulation), leading to a possible reinforced rated insulation voltage U_{Nm} of 2.668 kV.

In conclusion, the possible reinforced rated insulation voltage U_{Nm} in these conditions of use, is of 2.668 kV (the lowest value given by the both results from the creepage and clearance distances).

Key Six Sigma Statistics

Company Status	Sigma Level	Defect Free	Defects Per Million
Non Competitive	2	65%	308,537
Industry Average	3	93%	66,807
	4	99.4%	6,210
	5	99.976%	233
World Class	6	99.9997%	3.4

Source: Six Sigma Academy, Cambridge Management Consulting

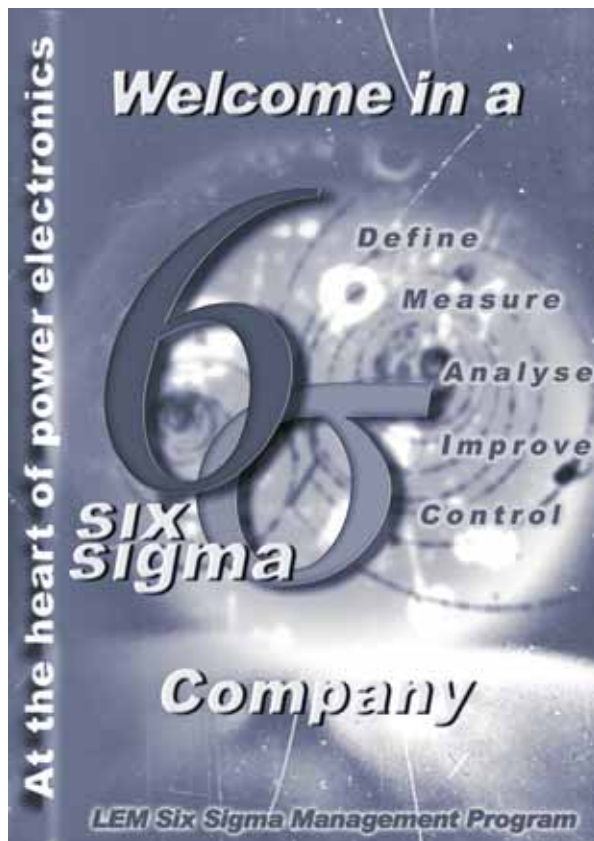

Solutions for Voltage Measurement



LV 25-P Family

LV 25-Voltage

AV 100-Voltage

CV 3-Voltage

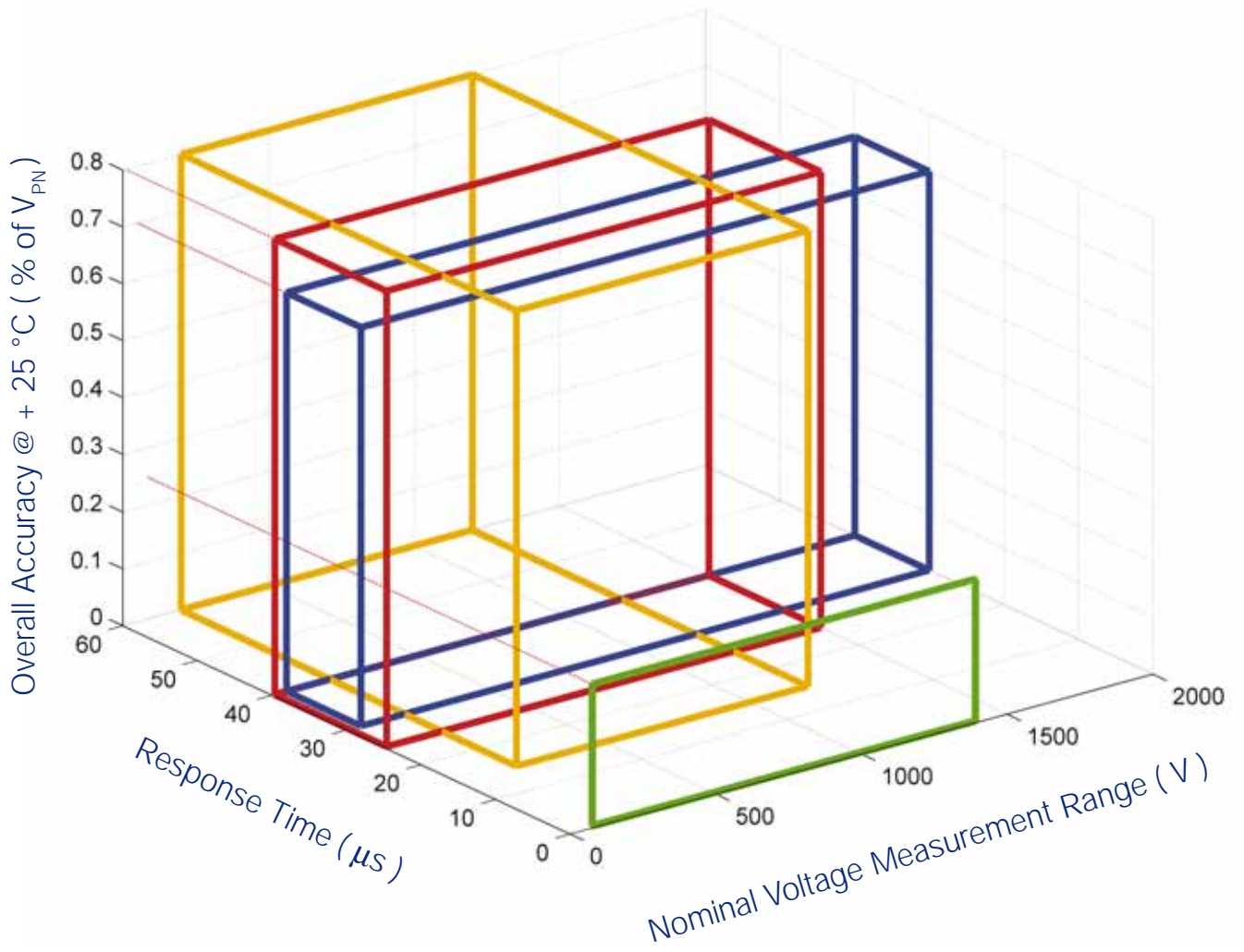



LV 100 Family



LV 100-Voltage



LV 200-AW/2/Voltage



CV 4-Voltage

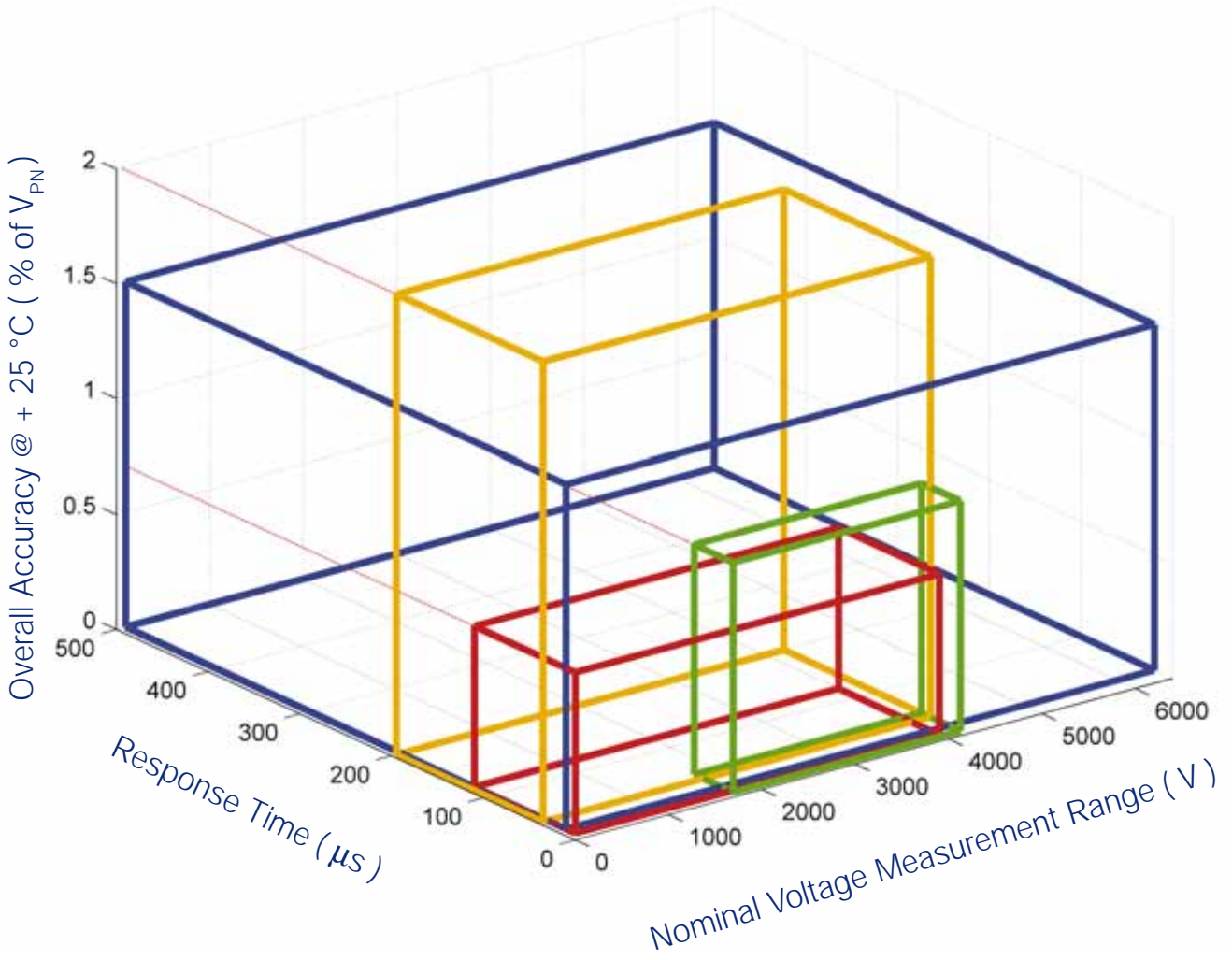

On-Board											
	Main circuit breaker	Main rectifier	DC Link	Auxiliary inverter	Propulsion inverter	SECONDARY SYSTEM					
						Power measurement	Lighting / plugs	HVAC	Doors Control	Battery Charger	
CURRENT MEASUREMENT	●		●	●	●	●					
	●		●	●	●	●					
				●	●	●					
				●	●	●		●	●		
				●	●	●		●	●		
				●	●	●		●	●		●
				●	●	●		●	●		●
				●	●	●		●	●		●
				●	●	●		●	●		●
				●	●	●		●	●		●
				●	●	●		●	●		●
				●	●	●		●	●		●
				●	●	●		●	●		●
				●	●	●		●	●		●
	VOLTAGE	●		●	●	●	●		●		
●			●	●	●	●		●			
		●		●	●	●		●			
		●		●	●	●		●			
		●		●	●	●		●			
		●		●	●	●		●			
		●		●	●	●		●			
		●		●	●	●		●			
		●		●	●	●		●			
		●		●	●	●		●			
		●		●	●	●		●			
		●		●	●	●		●			
		●		●	●	●		●			
		●		●	●	●		●			
ENERGY							●				

		Trackside			Substation		Product Solution	Nominal Range
Interference measurement	Points	Relays	Signaling	Switch-gear	Package represented on page n°			
						13	LT 505-S family	250-720 A
						13	LT 1005-S family	1000 A
						13	LT 2005-S family	1100-2000 A
					●	13	LT 4000-S family	4000-4400 A
						7 & 9	LTC family	350-1000 A
						11	LAC 300-S	300 A
						13	LA 205/305-S family	200-500 A
						11	LF 205-S family	100-200 A
						11	LF 305-S family	250-300 A
						11	LF 505-S family	500 A
						11	LF 1005-S family	1000 A
						11	LF 2005-S family	2000 A
						25	HTA family	250-1000 A
						15	HAR family	1000 A
						25	HTC family	500-3000 A
					●	21	LA 200..500 -SD family	200-500 A
					●	17	HAZ family	4000-20000 A
						23	LB family	2000 A
	●					23	CD family	2 x 1000 A, 2 A differential
						23	RA family	10-20 A AC Peak super-posed on 1000 to 3000 A DC
						29	CT -P family	0.1-0.4 A
		●			●	27	LA 25-NP family	0.25-25 A
		●				27	PCM family	10-30 A
					●	29	RCM family	2 A
		●			●	27	LTS family	6-25 A
					●	29	LV 25-P family	0.01 A
		●			●	32	LV 25-P family	10-1500 V
		●				32	LV 25-Voltage family	200-1200 V
					●	33	LV 100 family	100-4000 V
					●	15 & 33	LV 100-Voltage family	50-4200 V
						33	LV 200-AW/2/Voltage family	100-6400 V
						32	CV 3-Voltage family	85-1400 V
						20 & 33	CV 4-Voltage family	1767-4200 V
						20 & 32	AV 100-Voltage family	50-2000 V
						19	EM4T	

Various options for secondary connections



Molex 5045/A Series connector



JST VH Series Connector



Molex Mini-Fit, Jr 5566 Series Connector



Molex 70543 Series Connector



Threaded Studs, M4, M5, UNC...



...or Faston 6.30 x 0.80 or screws...



...or the both, in the same time



M4, M5 inserts



LEMO Connectors



AMP Connectors



Burndy Connectors



Sub-D Connectors



Cables, Shielded Cables...

But also Wago, Phoenix, Souriau ... connectors



CV : <input type="text"/>		LEM Subsidiary : <input type="text"/>		Contact : <input type="text"/>		Date : 24/08/06	
Customer information							
Company : <input type="text"/>		City : <input type="text"/>		Country : <input type="text"/>			
Contact person : <input type="text"/>		Phone : <input type="text"/>		Fax : <input type="text"/>			
Project name : <input type="text"/>		Category : K <input type="checkbox"/> T <input type="checkbox"/> A <input type="checkbox"/> B <input type="checkbox"/> C <input type="checkbox"/> D <input type="checkbox"/>					
Application							
Type	<input type="checkbox"/> industrial	<input type="checkbox"/> traction	<input type="checkbox"/> automotive	<input type="checkbox"/> process autom.	<input type="checkbox"/> other: <input type="text"/>		
Utilisation	<input type="checkbox"/> voltage	<input type="checkbox"/> current	<input type="checkbox"/> power	<input type="checkbox"/> other: <input type="text"/>			
Function	<input type="checkbox"/> control	<input type="checkbox"/> display	<input type="checkbox"/> ground fault detection				
	<input type="checkbox"/> detection	<input type="checkbox"/> differential measurement		<input type="checkbox"/> other (provide a separate descr.)			
Electrical & Environmental characteristics				Transducer reference (if relevant) : <input type="text"/>			
Signal to measure				Static and intrinsic values			
Type of signal : <input type="checkbox"/> AC sin. <input type="checkbox"/> DC				Global accuracy (% of nominal value, @ 25 °C)			
<input type="checkbox"/> square <input type="checkbox"/> pulse				<input type="text"/> %			
<input type="checkbox"/> other				Overall accuracy over operating temperature range			
<input type="checkbox"/> bidirectional <input type="checkbox"/> unidirectional				<input type="text"/> %			
Nominal value: <input type="text"/> rms				Maximum offset @ 25 °C			
Peak value <input type="text"/>				Dielectric strength			
(please provide a graph)				Primary/secondary (50 Hz/ 1 mn): <input type="text"/> kV rms			
Overload value to be measured: <input type="text"/> rms				Screen/secondary <input type="text"/> kV rms			
Peak: <input type="text"/>				PD Level @ 10 pC <input type="text"/> kV			
Duration : <input type="text"/> s				OV category: <input type="text"/> Pollution degree: <input type="text"/>			
Non measured overload (to withstand) <input type="text"/>				Power supply: <input type="text"/> V ± <input type="text"/> %			
Frequency: <input type="text"/> Hz				<input type="checkbox"/> bipolar <input type="checkbox"/> unipolar			
duration : <input type="text"/> ms				Preferred output <input type="text"/> <input type="checkbox"/> mA/A <input type="checkbox"/> mV/A			
di/dt to be followed: <input type="text"/> A/µs				<input type="text"/> <input type="checkbox"/> mA/V <input type="checkbox"/> mV/V			
Bandwidth : <input type="text"/> kHz				Turn ratio: <input type="text"/>			
Operating frequency: <input type="text"/> Hz				Temperature range			
Ripple : <input type="text"/> peak-peak				Operating : <input type="text"/> °C to <input type="text"/> °C			
Ripple frequency : <input type="text"/> Hz				Storage : <input type="text"/> °C to <input type="text"/> °C			
dv/dt applied on primary circuit: <input type="text"/> kV/µs							
Mechanical requirements							
Maximum dimensions required: L <input type="text"/> mm x W <input type="text"/> mm x H <input type="text"/> mm							
Mounting on : <input type="checkbox"/> PCB <input type="checkbox"/> Panel							
Output terminals : <input type="checkbox"/> PCB <input type="checkbox"/> Faston <input type="checkbox"/> Threaded studs M <input type="text"/> <input type="checkbox"/> Molex <input type="checkbox"/> Cable							
<input type="checkbox"/> other : <input type="text"/>							
Primary connection : <input type="checkbox"/> through hole : L <input type="text"/> mm x W <input type="text"/> mm ; or Ø <input type="text"/> mm							
<input type="checkbox"/> busbar L <input type="text"/> mm x W <input type="text"/> mm x H <input type="text"/> mm							
<input type="checkbox"/> other : <input type="text"/> For busbar, please provide lay-out							
Applicable standards: industrial <input type="checkbox"/> EN 50178 traction <input type="checkbox"/> EN 50155 other <input type="checkbox"/>							
If other, please specify : <input type="text"/>							
Project Management (amounts given in EUR)							
Financials Target price <input type="text"/> and Target cost <input type="text"/> or Gross margin <input type="text"/> %							
Total quantity for the project : <input type="text"/> and product life time <input type="text"/> or quantity per year <input type="text"/>							
Delivery :							
<input type="checkbox"/> Engineering samples		Quantity : <input type="text"/>		Date: <input type="text"/>			
<input type="checkbox"/> Prototype		Quantity : <input type="text"/>		Date: <input type="text"/>			
<input type="checkbox"/> Initial samples		Quantity : <input type="text"/>		Date: <input type="text"/>			
<input type="checkbox"/> Serie 1		Quantity : <input type="text"/>		Date: <input type="text"/>			
Required response time <input type="text"/>				Order probability <input type="text"/> %			

Dimension Drawings

All dimensions are in mm

● Hall effect chip location

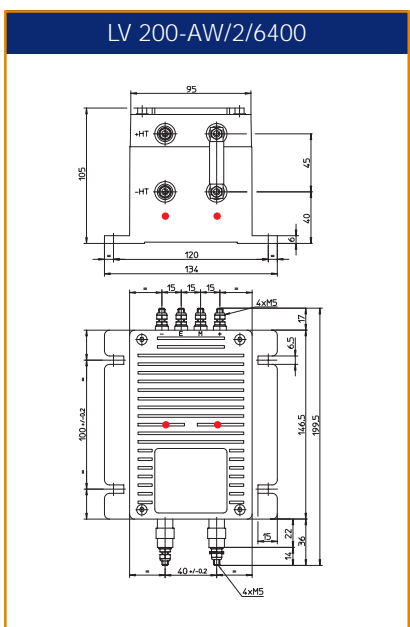
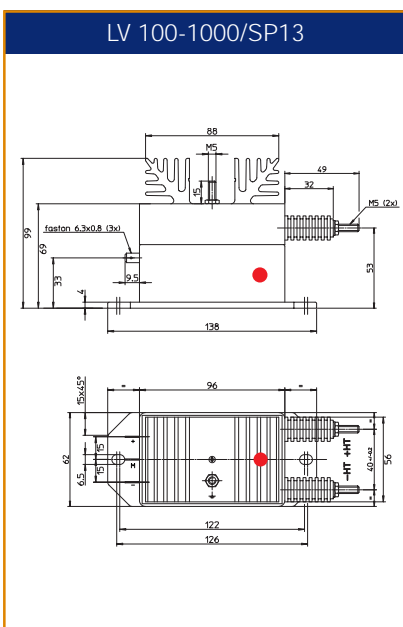
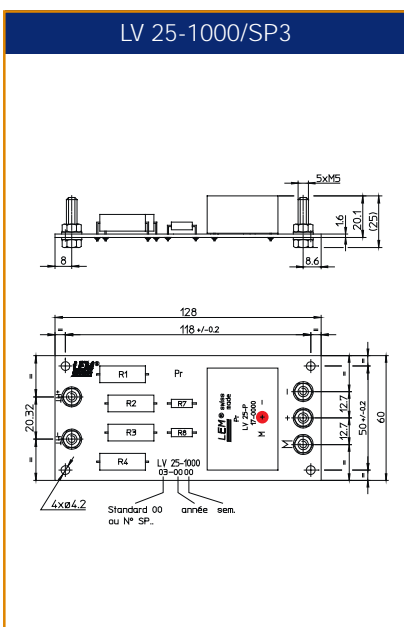
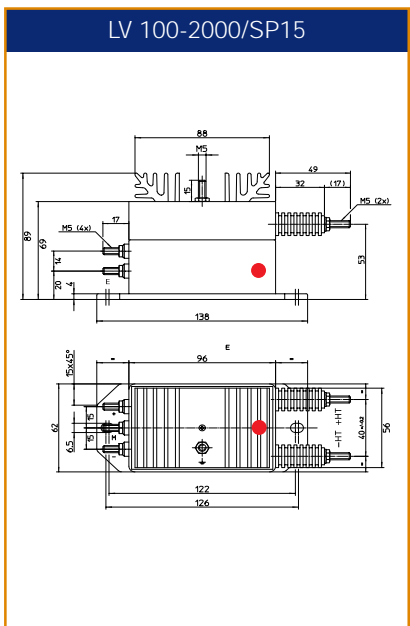
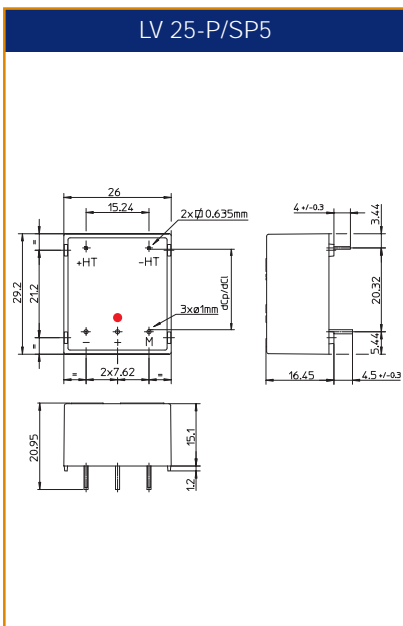
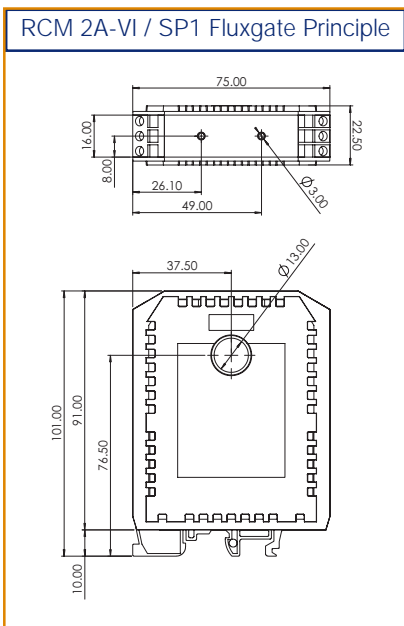
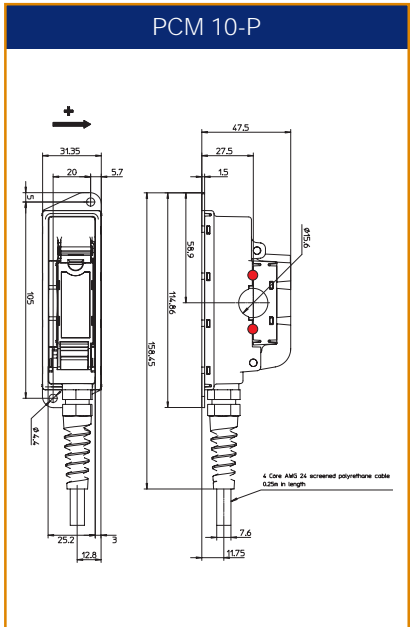
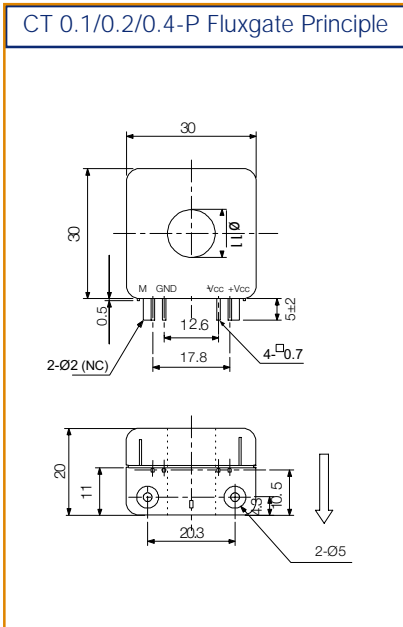
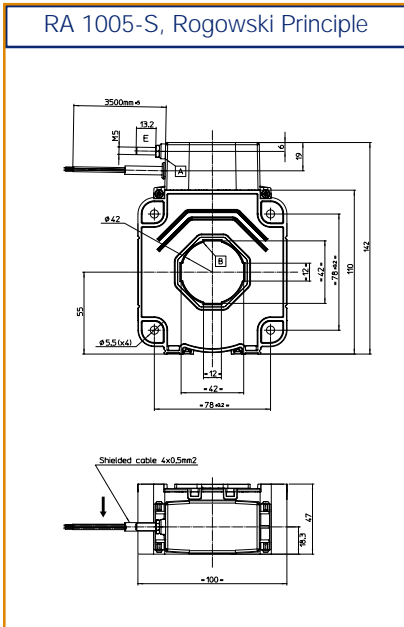

Dimension Drawings

All dimensions are in mm

● Hall effect chip location

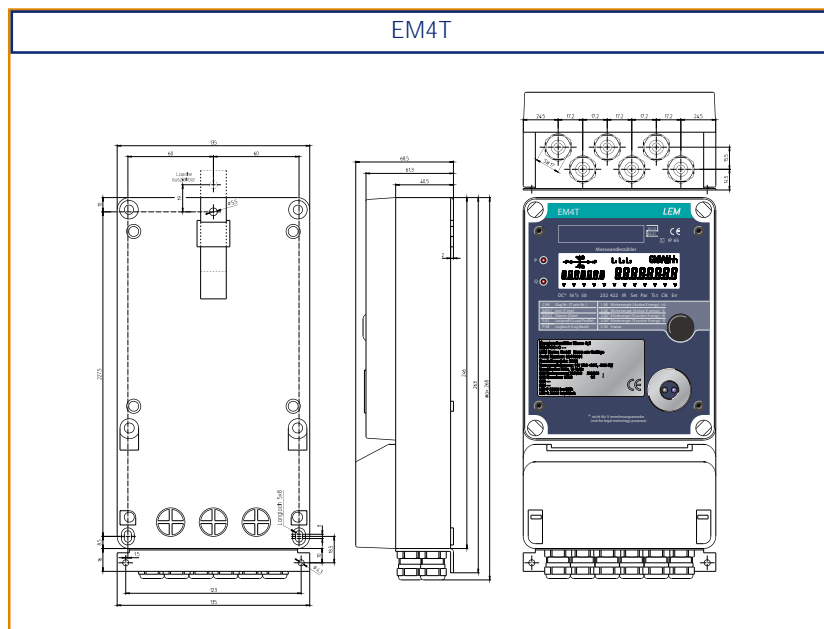
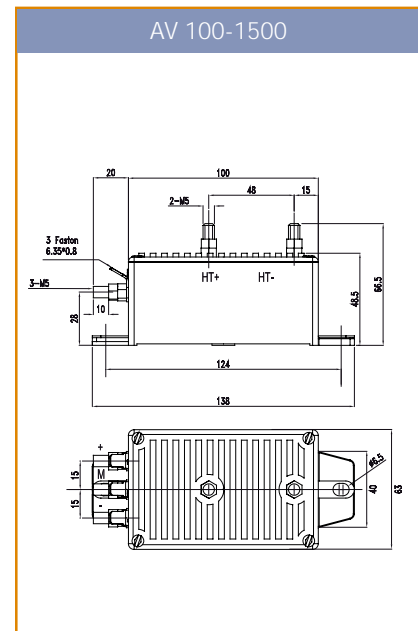
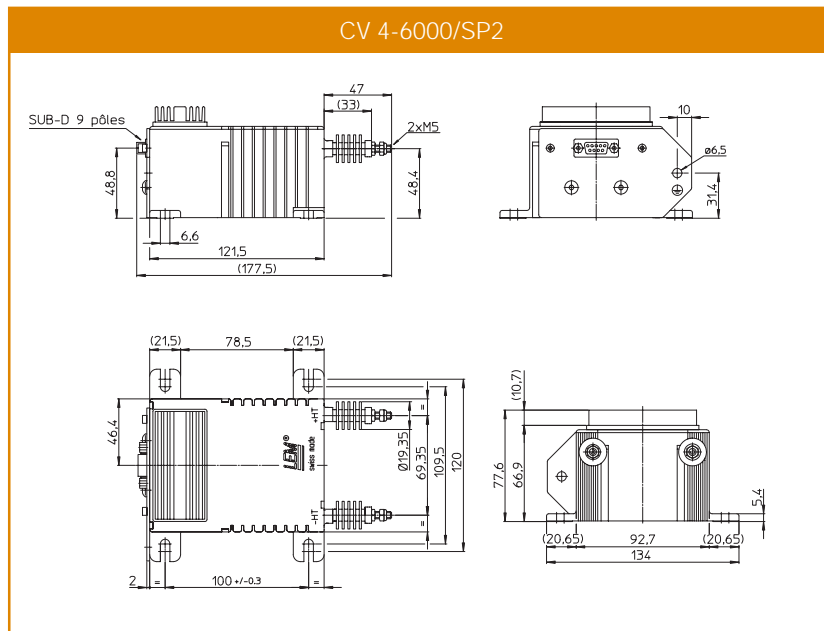
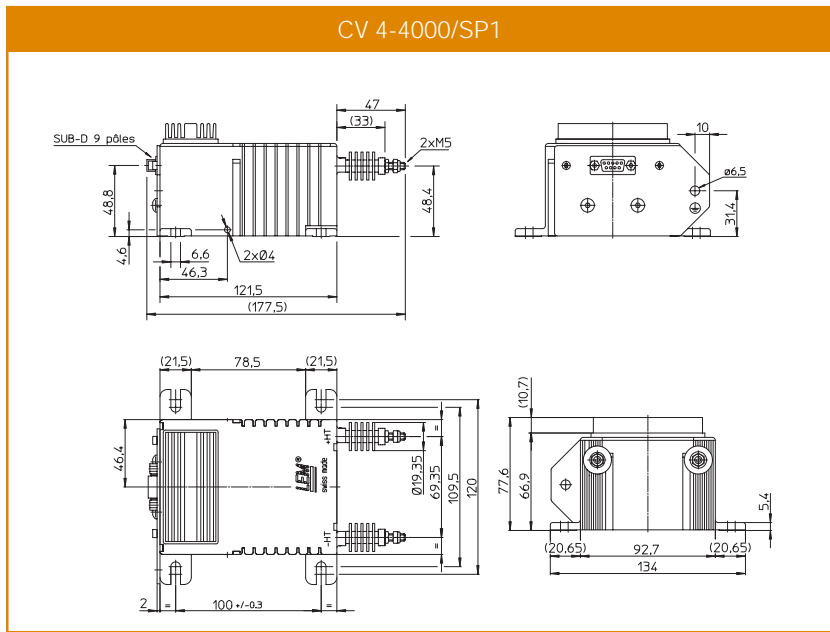
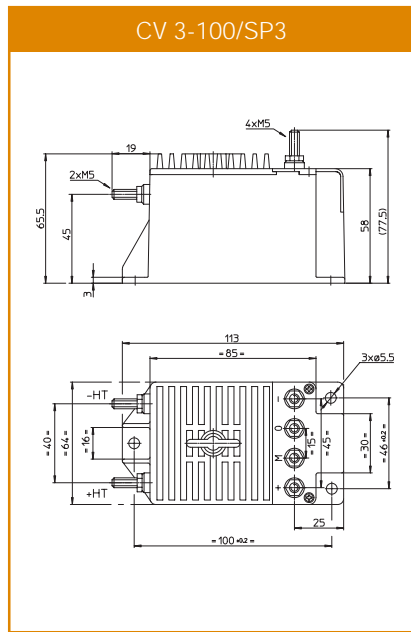



5 Years Warranty on LEM Transducers

LEM designs and manufactures high quality and high reliability products for its customers over the entire world.

Since 1972, we have delivered several million current and voltage transducers which are, for most of them, still in operation on traction vehicles, industrial motor drives, UPS systems and many other applications requiring high quality standards.

Our 5 years warranty applies on all LEM transducers delivered from the 1st. of January 1996 and is valid in addition to the legal warranty.

The warranty granted on our Transducers is for a period of 5 years (60 months) from the date of their delivery.

During this period we shall replace or repair at our cost all defective parts (provided the defect is due to defective material or workmanship).

Further claims as well as claims for the compensation of damages, which do not occur on the delivered material itself, are not covered by this warranty.

All defects must be notified to us immediately and faulty material must be returned to the factory along with a description of the defect.

Warranty repairs and or replacements are carried out at our discretion. The customer bears the transport costs. An extension of the warranty period following repairs undertaken under warranty cannot be granted.

The warranty will be invalidated if the buyer has modified or repaired, or has had repaired by a third party the material without LEM's written consent.

The warranty does not cover any damage caused by incorrect conditions of use and cases of force majeure. No responsibility will apply except legal requirements regarding product liability.

The warranty explicitly excludes all claims exceeding the above conditions.

LEM, Geneva, January 1. 2001

A handwritten signature in black ink, appearing to read "P. Van Iseghem".

Paul Van Iseghem
President & CEO LEM